

SETTING AND OPERATING INSTRUCTIONS

Monaghan OD style 5452 roller burnishing tool

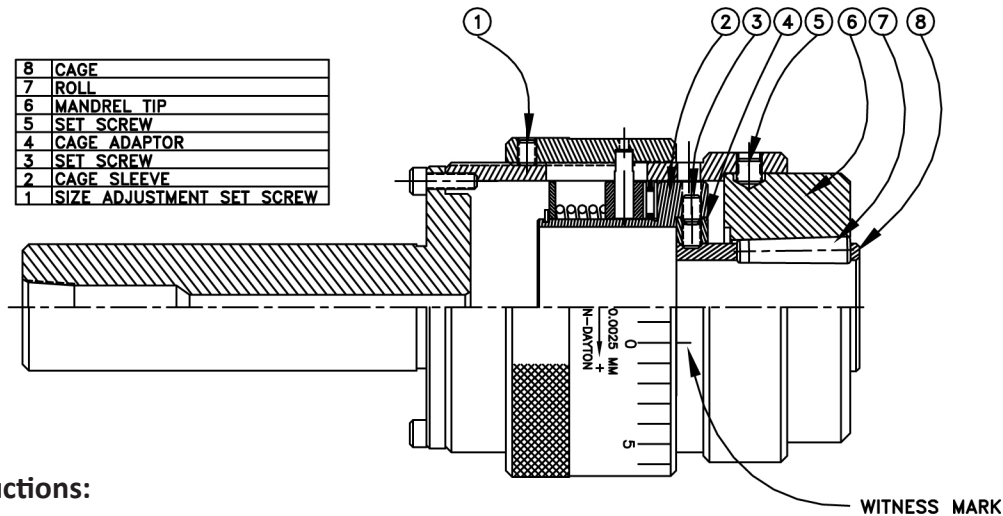

Assembly instructions:

To replace the cage, mandrel or rolls, use the following steps:

- 1) Loosen the three (3) cage sleeve set screws (detail 3).
- 2) Loosen the three (3) mandrel tip set screws (detail 5).

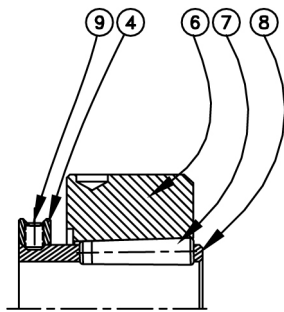

Once the two (2) set screws have been loosened, you will be able to remove the mandrel tip, cage and rolls from the housing as shown to the left.

On tool diameters between .500 and 1.250 inches, there will be a cage adapter (detail 4). Loosen the three (3) set screws (detail 9) and remove the cage adapter. The cage and roll can then be removed from the mandrel tip.

Replace the worn components and reassemble the tool.

Setting instructions:

To set the tool diameter, loosen the size adjustment set screw (detail 1). When holding the shank of the tool, rotate counter-clockwise to decrease the diameter and clockwise to increase the diameter.

Using a part that has been prepared for burnishing, slide the tool over the part and decrease the diameter until the rolls make contact with the surface. Remove the tool from the part and decrease the tool diameter using the witness mark and the incremented diameter adjustments. Each mark equals .0001 inches. The tool should be decreased based on the amount of stock left for burnishing.

After the diameter has been set, tighten the set screw (detail 1).