

The reamer specialist



# Reamers

---



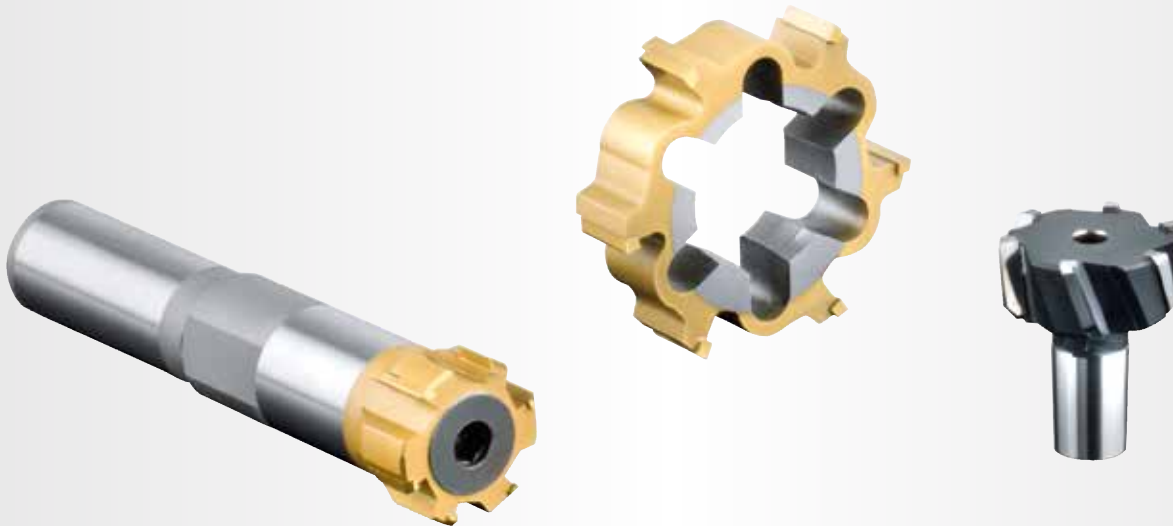

**DIATOO**'s 10 strong points:

1. More than 30 years of experience in the manufacturing and repair of multi-bladed reamers
2. Short delivery times for standard and special reamers
3. Competitive prices
4. DIATOO concentrates on the core business "reaming"
5. Highest product quality
6. Newest technology
7. Application related consulting
8. Deep and wide product range
9. Large choice of cutting materials and coatings
10. Worldwide network of distributors and dealers

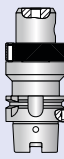
Chapter	Products	Page
	<b>Monoblock Reamers</b> Monoblock, solid and expandable	4 - 17
	<b>Reaming Heads + Holders</b> Modular, solid	18 - 25
	<b>Cutting Rings + Holders</b> Modular, expandable	26 - 37
	<b>DIATool Top Speed Ring + Holders</b> Modular, solid	38 - 47
<b>S</b>	<b>Special Reamers</b>	48 - 49
	<b>Compensation Holders</b> HSK SK / ISO CAT MAS BT	50 - 65
	<b>Floating Holder</b> Cyl. VDI HSK	66 - 71
<b>i</b>	<b>Information</b> Overview Geometry Recommendations Cutting data Correction of reaming problems Questionnaire Repair service Media	72 - 73 74 75 76 - 79 80 81 82 83



## Monoblock Reamers

### Product Features:







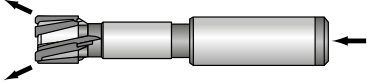
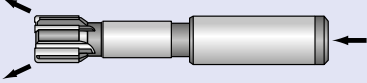
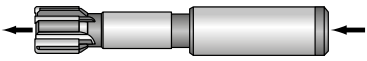

- Solid and expandable  $\varnothing$  5,600 – 60,599 mm (on request up to  $\varnothing$  100,599 mm)
- With and without internal coolant supply
- Short and long version
- Different cutting materials and coatings

### Product Advantages:

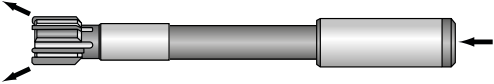
- Very stable thanks to the monoblock design = excellent bore quality
- All reamers are ground to the nominal size, e.g. first bore = good bore!
- No diameter setting
- Short machining times thanks to high feeds and multi-blade design
- Wear compensation through the simple expansion feature
- High economic efficiency thanks to repeated retippings
- Repaired/retipped reamers have the same tool life as new reamers

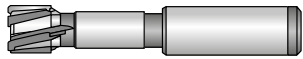
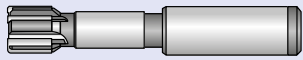
# Monoblock Reamers

The reamer specialist

Type	ø range mm		Page
3250 3450	7,900 - 60,599 7,900 - 60,599		6
3251 3451	5,600 - 60,599 5,600 - 60,599		7
3252 3452	5,600 - 60,599 5,600 - 60,599		8
3260 3460	7,900 - 60,599 7,900 - 60,599		9
3261 3461	5,600 - 60,599 5,600 - 60,599		10
3262 3462	5,600 - 60,599 5,600 - 60,599		11
2250 2450	7,900 - 60,599 7,900 - 60,599		12
2251 2451	5,600 - 60,599 5,600 - 60,599		13
2260 2460	7,900 - 60,599 7,900 - 60,599		14
2261 2461	5,600 - 60,599 5,600 - 60,599		15
2361	5,600 - 21,599		16
Handling instructions			17



Monoblock Reamers

**Monoblock Reamer, short**

Left hand fluted

With internal coolant supply for through holes

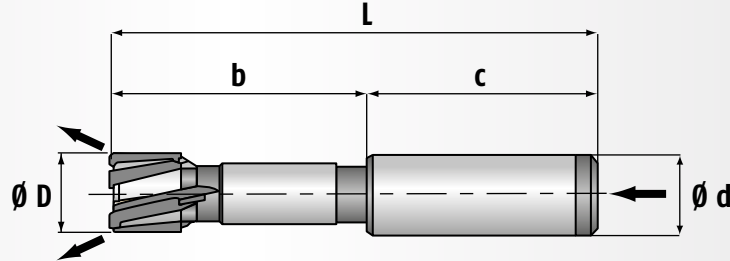

Type 3250 Solid		Type 3450 Expandable	
HM (Carbide)	CT (CERMET)	HM (Carbide)	CT (CERMET)
3250 HM	3250 CT	3450 HM	3450 CT
3250 HM-TiN	3250 CT-TiAlN	3450 HM-TiN	3450 CT-TiAlN
3250 HM-TiAlN	3250 CT-TiAlN-P	3450 HM-TiAlN	3450 CT-TiAlN-P
3250 HM-TiAlN-P	3250 CT-ATN	3450 HM-TiAlN-P	3450 CT-ATN
3250 HM-TiAlN-L		3450 HM-TiAlN-L	
3250 HM-ATN		3450 HM-ATN	
3250 HM-ATC		3450 HM-ATC	
3250 HM-ZCN		3450 HM-ZCN	

Bevel lead geometry see page 74

Coating recommendations see page 78 - 79

PCD on request

Ø D mm	L mm	b mm	c mm	Ø d mm (h6)	No. of teeth
7,900 - 9,899	85	40	45	12	4
9,900 - 11,899	95	50	45	12	4
11,900 - 15,899	95	50	45	12	6
15,900 - 18,899	100	50	50	16	6
18,900 - 25,899	120	60	60	20	6
25,900 - 32,599	135	75	60	25	6
32,600 - 40,599	135	75	60	25	8
40,600 - 50,599	135	75	60	25	8
50,600 - 60,599	135	75	60	32	8

- Recommended cutting data page 76 - 79
- Larger diameters on request (up to Ø 100,599 mm)
- Smaller shank diameters are possible
- Clamping flats to customer specification
- Short delivery times for other length dimensions
- Retipping and recoating possible

Suitable for the following bores

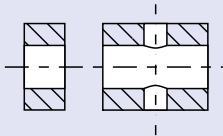

Order example:	Article no.	Bore Ø	Bore tolerance	Bevel lead geometry
	3450 CT-ATN	18	H7	G05

# Type 3251, 3451

The reamer specialist

## Monoblock Reamer, short

Straight fluted

With internal coolant supply for through and blind holes

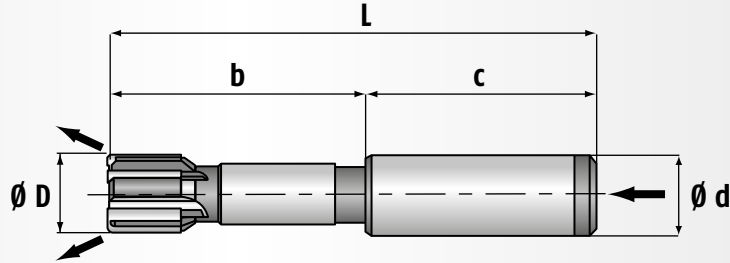

Type 3251 Solid		Type 3451 Expandable	
HM (Carbide)	CT (CERMET)	HM (Carbide)	CT (CERMET)
3251 HM	3251 CT	3451 HM	3451 CT
3251 HM-TiN	3251 CT-TiAIN	3451 HM-TiN	3451 CT-TiAIN
3251 HM-TiAIN	3251 CT-TiAIN-P	3451 HM-TiAIN	3451 CT-TiAIN-P
3251 HM-TiAIN-P	3251 CT-ATN	3451 HM-TiAIN-P	3451 CT-ATN
3251 HM-TiAIN-L		3451 HM-TiAIN-L	
3251 HM-ATN		3451 HM-ATN	
3251 HM-ATC		3451 HM-ATC	
3251 HM-ZCN		3451 HM-ZCN	

Bevel lead geometry see page 74

Coating recommendations see page 76 - 77

PCD on request

Ø D mm	L mm	b mm	c mm	Ø d mm (h6)	No. of teeth
5,600 - 8,899	85	40	45	12	4
8,900 - 15,899	95	50	45	12	6
15,900 - 18,899	100	50	50	16	6
18,900 - 25,899	120	60	60	20	6
25,900 - 32,599	135	75	60	25	6
32,600 - 40,599	135	75	60	25	8
40,600 - 50,599	135	75	60	25	8
50,600 - 60,599	135	75	60	32	8

- Recommended cutting data page 76 - 79
- Larger diameters on request (up to Ø 100,599 mm)
- Smaller shank diameters are possible
- Clamping flats to customer specification
- Short delivery times for other length dimensions
- Retipping and recoating possible

Suitable for the following bores

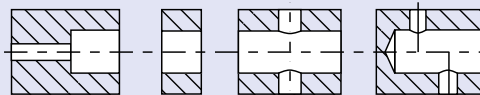

Order example:

Article no.  
3451 CT-ATN

Bore ø  
16

Bore tolerance  
H7

Bevel lead geometry  
G01

## Monoblock Reamer, short

Straight fluted

With internal coolant supply for blind holes

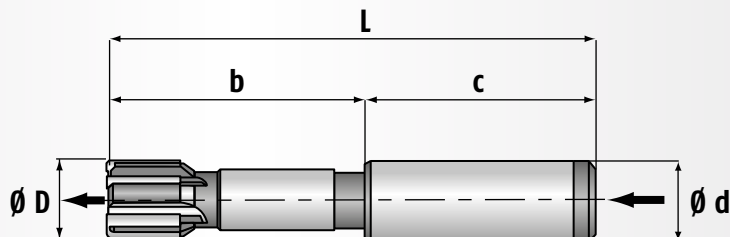

Type 3252 Solid		Type 3452 Expandable	
HM (Carbide)	CT (CERMET)	HM (Carbide)	CT (CERMET)
3252 HM	3252 CT	3452 HM	3452 CT
3252 HM-TiN	3252 CT-TiAlN	3452 HM-TiN	3452 CT-TiAlN
3252 HM-TiAlN	3252 CT-TiAlN-P	3452 HM-TiAlN	3452 CT-TiAlN-P
3252 HM-TiAlN-P	3252 CT-ATN	3452 HM-TiAlN-P	3452 CT-ATN
3252 HM-TiAlN-L		3452 HM-TiAlN-L	
3252 HM-ATN		3452 HM-ATN	
3252 HM-ATC		3452 HM-ATC	
3252 HM-ZCN		3452 HM-ZCN	

Bevel lead geometry see page 74

Coating recommendations see page 76 - 77

PCD on request

Ø D mm	L mm	b mm	c mm	Ø d mm (h6)	No. of teeth
5,600 - 8,899	85	40	45	12	4
8,900 - 15,899	95	50	45	12	6
15,900 - 18,899	100	50	50	16	6
18,900 - 25,899	120	60	60	20	6
25,900 - 32,599	135	75	60	25	6
32,600 - 40,599	135	75	60	25	8
40,600 - 50,599	135	75	60	25	8
50,600 - 60,599	135	75	60	32	8

- Recommended cutting data page 76 - 79
- Larger diameters on request (up to Ø 100,599 mm)
- Smaller shank diameters are possible
- Clamping flats to customer specification
- Short delivery times for other length dimensions
- Retipping and recoating possible

Suitable for the following bores

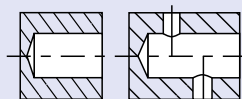

Order example:

Article no.  
3452 CT-ATN

Bore ø  
20

Bore tolerance  
H7

Bevel lead geometry  
G01



**Monoblock Reamer, long**

Left hand fluted

With internal coolant supply for through holes

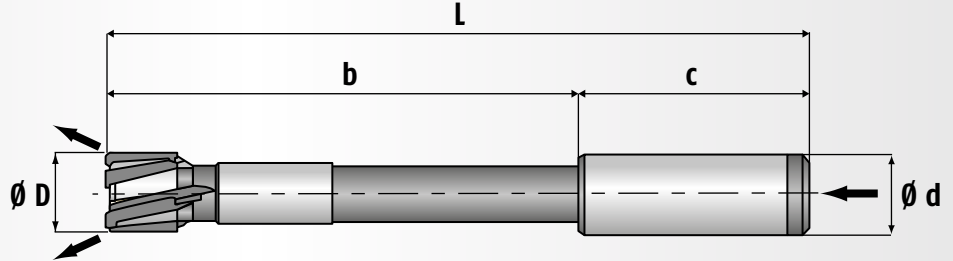

Type 3260 Solid		Type 3460 Expandable	
HM (Carbide)	CT (CERMET)	HM (Carbide)	CT (CERMET)
3260 HM	3260 CT	3460 HM	3460 CT
3260 HM-TiN	3260 CT-TiAlN	3460 HM-TiN	3460 CT-TiAlN
3260 HM-TiAlN	3260 CT-TiAlN-P	3460 HM-TiAlN	3460 CT-TiAlN-P
3260 HM-TiAlN-P	3260 CT-ATN	3460 HM-TiAlN-P	3460 CT-ATN
3260 HM-TiAlN-L		3460 HM-TiAlN-L	
3260 HM-ATN		3460 HM-ATN	
3260 HM-ATC		3460 HM-ATC	
3260 HM-ZCN		3460 HM-ZCN	

Bevel lead geometry see page 74

Coating recommendations see page 78 - 79

PCD on request

Ø D mm	L mm	b mm	c mm	Ø d mm (h6)	No. of teeth
7,900 - 9,899	130	85	45	12	4
9,900 - 11,899	160	115	45	12	4
11,900 - 15,899	160	115	45	12	6
15,900 - 18,899	180	130	50	16	6
18,900 - 25,899	200	140	60	20	6
25,900 - 32,599	210	150	60	25	6
32,600 - 40,599	210	150	60	25	8
40,600 - 50,599	210	150	60	25	8
50,600 - 60,599	210	150	60	32	8

- Recommended cutting data page 76 - 79
- Larger diameters on request (up to Ø 100,599 mm)
- Smaller shank diameters are possible
- Clamping flats to customer specification
- Short delivery times for other length dimensions
- Retipping and recoating possible

Suitable for the following bores

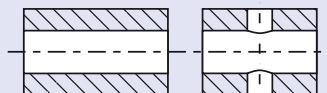

Order example:

Article no.  
3460 CT-ATN

Bore ø  
16

Bore tolerance  
H7

Bevel lead geometry  
G05

**Monoblock Reamer, long**

Straight fluted

With internal coolant supply for through and blind holes

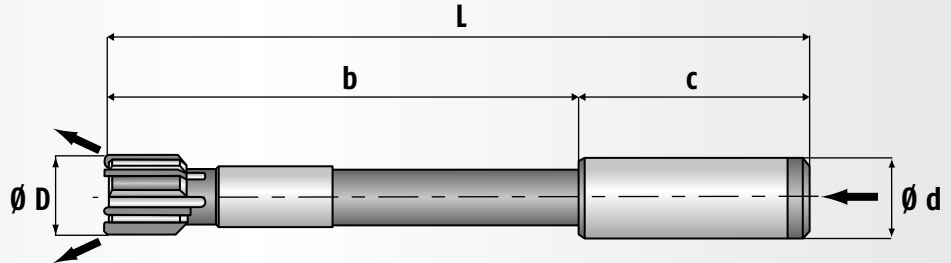

Type 3261 Solid		Type 3461 Expandable	
HM (Carbide)	CT (CERMET)	HM (Carbide)	CT (CERMET)
3261 HM	3261 CT	3461 HM	3461 CT
3261 HM-TiN	3261 CT-TiAlN	3461 HM-TiN	3461 CT-TiAlN
3261 HM-TiAlN	3261 CT-TiAlN-P	3461 HM-TiAlN	3461 CT-TiAlN-P
3261 HM-TiAlN-P	3261 CT-ATN	3461 HM-TiAlN-P	3461 CT-ATN
3261 HM-TiAlN-L		3461 HM-TiAlN-L	
3261 HM-ATN		3461 HM-ATN	
3261 HM-ATC		3461 HM-ATC	
3261 HM-ZCN		3461 HM-ZCN	

Bevel lead geometry see page 74

Coating recommendations see page 76 - 77

PCD on request

Ø D mm	L mm	b mm	c mm	Ø d mm (h6)	No. of teeth
5,600 - 8,899	130	85	45	12	4
8,900 - 9,899	130	85	45	12	6
9,900 - 15,899	160	115	45	12	6
15,900 - 18,899	180	130	50	16	6
18,900 - 25,899	200	140	60	20	6
25,900 - 32,599	210	150	60	25	6
32,600 - 40,599	210	150	60	25	8
40,600 - 50,599	210	150	60	25	8
50,600 - 60,599	210	150	60	32	8

- Recommended cutting data page 76 - 79
- Larger diameters on request (up to Ø 100,599 mm)
- Smaller shank diameters are possible
- Clamping flats to customer specification
- Short delivery times for other length dimensions
- Retipping and recoating possible

Suitable for the following bores

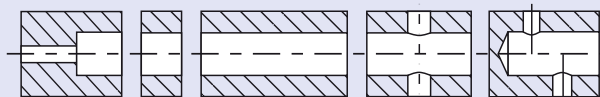

Order example:	Article no.	Bore Ø	Bore tolerance	Bevel lead geometry
	3461 CT-ATN	18	H7	G11

**Monoblock Reamer, long**  
**Straight fluted**  
**With internal coolant supply for blind holes**

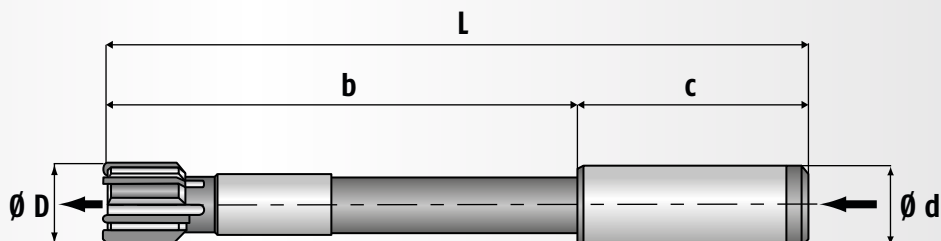

Type 3262 Solid		Type 3462 Expandable	
HM (Carbide)	CT (CERMET)	HM (Carbide)	CT (CERMET)
3262 HM	3262 CT	3462 HM	3462 CT
3262 HM-TiN	3262 CT-TiAlN	3462 HM-TiN	3462 CT-TiAlN
3262 HM-TiAlN	3262 CT-TiAlN-P	3462 HM-TiAlN	3462 CT-TiAlN-P
3262 HM-TiAlN-P	3262 CT-ATN	3462 HM-TiAlN-P	3462 CT-ATN
3262 HM-TiAlN-L		3462 HM-TiAlN-L	
3262 HM-ATN		3462 HM-ATN	
3262 HM-ATC		3462 HM-ATC	
3262 HM-ZCN		3462 HM-ZCN	

Bevel lead geometry see page 74  
 Coating recommendations see page 76 - 77  
 PCD on request

Ø D mm	L mm	b mm	c mm	Ø d mm (h6)	No. of teeth
5,600 - 8,899	130	85	45	12	4
8,900 - 9,899	130	85	45	12	6
9,900 - 15,899	160	115	45	12	6
15,900 - 18,899	180	130	50	16	6
18,900 - 25,899	200	140	60	20	6
25,900 - 32,599	210	150	60	25	6
32,600 - 40,599	210	150	60	25	8
40,600 - 50,599	210	150	60	25	8
50,600 - 60,599	210	150	60	32	8

- Recommended cutting data page 76 - 79
- Larger diameters on request (up to Ø 100,599 mm)
- Smaller shank diameters are possible
- Clamping flats to customer specification
- Short delivery times for other length dimensions
- Retipping and recoating possible

Suitable for the following bores

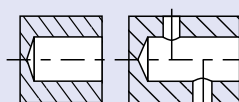

Order example:	Article no.	Bore Ø	Bore tolerance	Bevel lead geometry
	3462 CT-ATN	18	H7	G01

**Monoblock Reamer, short**  
**Left hand fluted**  
**Without internal coolant supply**

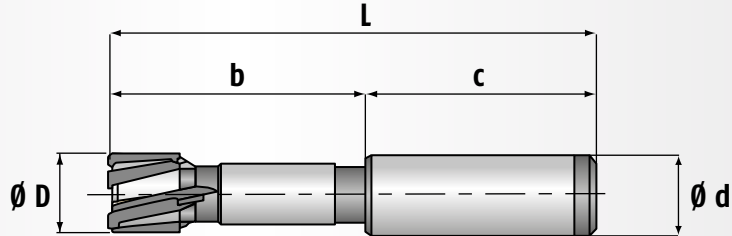

Type 2250 Solid		Type 2450 Expandable	
HM (Carbide)	CT (CERMET)	HM (Carbide)	CT (CERMET)
2250 HM	2250 CT	2450 HM	2450 CT
2250 HM-TiN	2250 CT-TiAlN	2450 HM-TiN	2450 CT-TiAlN
2250 HM-TiAlN	2250 CT-TiAlN-P	2450 HM-TiAlN	2450 CT-TiAlN-P
2250 HM-TiAlN-P	2250 CT-ATN	2450 HM-TiAlN-P	2450 CT-ATN
2250 HM-TiAlN-L		2450 HM-TiAlN-L	
2250 HM-ATN		2450 HM-ATN	
2250 HM-ATC		2450 HM-ATC	
2250 HM-ZCN		2450 HM-ZCN	

Bevel lead geometry see page 74  
 Coating recommendations see page 78 - 79  
 PCD on request

Ø D mm	L mm	b mm	c mm	Ø d mm (h6)	No. of teeth
7,900 - 9,899	85	40	45	12	4
9,900 - 11,899	95	50	45	12	4
11,900 - 15,899	95	50	45	12	6
15,900 - 18,899	100	50	50	16	6
18,900 - 25,899	120	60	60	20	6
25,900 - 32,599	135	75	60	25	6
32,600 - 40,599	135	75	60	25	8
40,600 - 50,599	135	75	60	25	8
50,600 - 60,599	135	75	60	32	8

- Recommended cutting data page 76 - 79
- Larger diameters on request (up to Ø 100,599 mm)
- Smaller shank diameters are possible
- Clamping flats to customer specification
- Short delivery times for other length dimensions
- Retipping and recoating possible

Suitable for the following bores

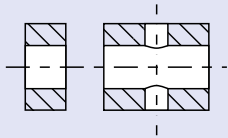

Order example:	Article no.	Bore Ø	Bore tolerance	Bevel lead geometry
	2450 CT-ATN	18	H7	G05

# Type 2251, 2451

The reamer specialist

**Monoblock Reamer, short**  
**Straight fluted**  
**Without internal coolant supply**

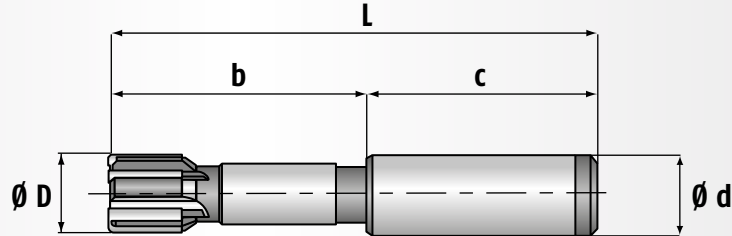

Type 2251 Solid		Type 2451 Expandable	
HM (Carbide)	CT (CERMET)	HM (Carbide)	CT (CERMET)
2251 HM	2251 CT	2451 HM	2451 CT
2251 HM-TiN	2251 CT-TiAlN	2451 HM-TiN	2451 CT-TiAlN
2251 HM-TiAlN	2251 CT-TiAlN-P	2451 HM-TiAlN	2451 CT-TiAlN-P
2251 HM-TiAlN-P	2251 CT-ATN	2451 HM-TiAlN-P	2451 CT-ATN
2251 HM-TiAlN-L		2451 HM-TiAlN-L	
2251 HM-ATN		2451 HM-ATN	
2251 HM-ATC		2451 HM-ATC	
2251 HM-ZCN		2451 HM-ZCN	

Bevel lead geometry see page 74  
 Coating recommendations see page 76 - 77  
 PCD on request

Ø D mm	L mm	b mm	c mm	Ø d mm (h6)	No. of teeth
5,600 - 8,899	85	40	45	12	4
8,900 - 15,899	95	50	45	12	6
15,900 - 18,899	100	50	50	16	6
18,900 - 25,899	120	60	60	20	6
25,900 - 32,599	135	75	60	25	6
32,600 - 40,599	135	75	60	25	8
40,600 - 50,599	135	75	60	25	8
50,600 - 60,599	135	75	60	32	8

- Recommended cutting data page 76 - 79
- Larger diameters on request (up to Ø 100,599 mm)
- Smaller shank diameters are possible
- Clamping flats to customer specification
- Short delivery times for other length dimensions
- Retipping and recoating possible

Suitable for the following bores

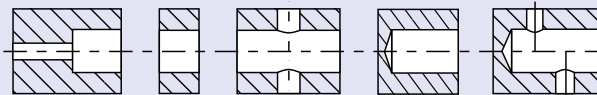

Order example:	Article no.	Bore Ø	Bore tolerance	Bevel lead geometry
	2451 CT-ATN	18	H7	G01

**Monoblock Reamer, long**  
**Left hand fluted**  
**Without internal coolant supply**

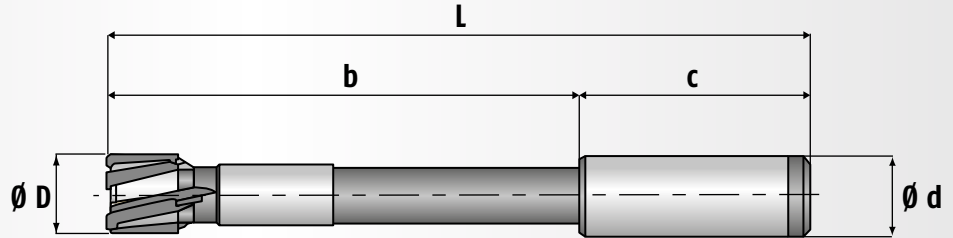

Type 2260 Solid		Type 2460 Expandable	
HM (Carbide)	CT (CERMET)	HM (Carbide)	CT (CERMET)
2260 HM	2260 CT	2460 HM	2460 CT
2260 HM-TiN	2260 CT-TiAlN	2460 HM-TiN	2460 CT-TiAlN
2260 HM-TiAlN	2260 CT-TiAlN-P	2460 HM-TiAlN	2460 CT-TiAlN-P
2260 HM-TiAlN-P	2260 CT-ATN	2460 HM-TiAlN-P	2460 CT-ATN
2260 HM-TiAlN-L		2460 HM-TiAlN-L	
2260 HM-ATN		2460 HM-ATN	
2260 HM-ATC		2460 HM-ATC	
2260 HM-ZCN		2460 HM-ZCN	

Bevel lead geometry see page 74  
 Coating recommendations see page 78 - 79  
 PCD on request

Ø D mm	L mm	b mm	c mm	Ø d mm (h6)	No. of teeth
7,900 - 9,899	130	85	45	12	4
9,900 - 11,899	160	115	45	12	4
11,900 - 15,899	160	115	45	12	6
15,900 - 18,899	180	130	50	16	6
18,900 - 25,899	200	140	60	20	6
25,900 - 32,599	210	150	60	25	6
32,600 - 40,599	210	150	60	25	8
40,600 - 50,599	210	150	60	25	8
50,600 - 60,599	210	150	60	32	8

- Recommended cutting data page 76 - 79
- Larger diameters on request (up to Ø 100,599 mm)
- Smaller shank diameters are possible
- Clamping flats to customer specification
- Short delivery times for other length dimensions
- Retipping and recoating possible

Suitable for the following bores

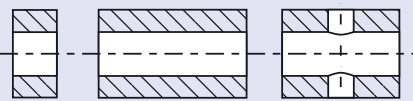

Order example:	Article no.	Bore ø	Bore tolerance	Bevel lead geometry
	2460 CT-ATN	18	H7	G05

# Type 2261, 2461

The reamer specialist

**Monoblock Reamer, long**  
**Straight fluted**  
**Without internal coolant supply**

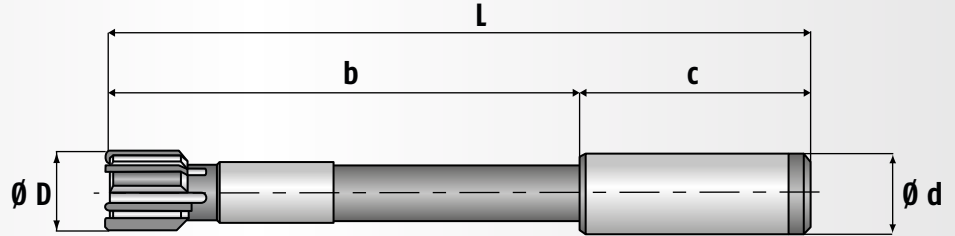

Type 2261 Solid		Type 2461 Expandable	
HM (Carbide)	CT (CERMET)	HM (Carbide)	CT (CERMET)
2261 HM	2261 CT	2461 HM	2461 CT
2261 HM-TiN	2261 CT-TiAIN	2461 HM-TiN	2461 CT-TiAIN
2261 HM-TiAIN	2261 CT-TiAIN-P	2461 HM-TiAIN	2461 CT-TiAIN-P
2261 HM-TiAIN-P	2261 CT-ATN	2461 HM-TiAIN-P	2461 CT-ATN
2261 HM-TiAIN-L		2461 HM-TiAIN-L	
2261 HM-ATN		2461 HM-ATN	
2261 HM-ATC		2461 HM-ATC	
2261 HM-ZCN		2461 HM-ZCN	

Bevel lead geometry see page 74  
 Coating recommendations see page 76 - 77  
 PCD on request

Ø D mm	L mm	b mm	c mm	Ø d mm (h6)	No. of teeth
5,600 - 8,899	130	85	45	12	4
8,900 - 9,899	130	85	45	12	6
9,900 - 15,899	160	115	45	12	6
15,900 - 18,899	180	130	50	16	6
18,900 - 25,899	200	140	60	20	6
25,900 - 32,599	210	150	60	25	6
32,600 - 40,599	210	150	60	25	8
40,600 - 50,599	210	150	60	25	8
50,600 - 60,599	210	150	60	32	8

- Recommended cutting data page 76 - 79
- Larger diameters on request (up to Ø 100,599 mm)
- Smaller shank diameters are possible
- Clamping flats to customer specification
- Short delivery times for other length dimensions
- Retipping and recoating possible

Suitable for the following bores

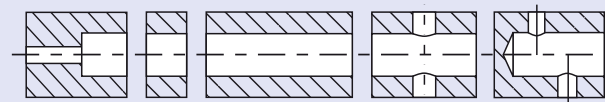

Order example:	Article no.	Bore Ø	Bore tolerance	Bevel lead geometry
	2461 CT-ATN	18	H7	G01

**Monoblock Reamer, long**  
 Straight fluted  
 Without internal coolant supply

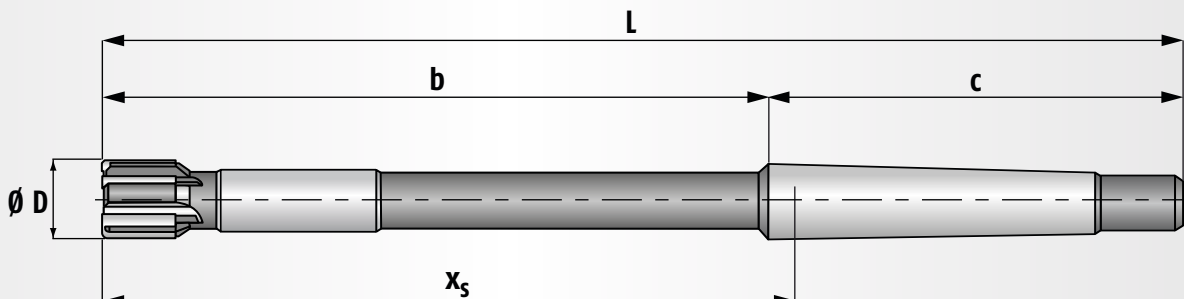

### Type 2361 Expandable

2361 HM (Carbide)

Bevel lead geometry see page 74  
 Coating recommendations see page 76 - 77

Ø D mm	L mm	b mm	x <sub>s</sub> mm	c mm	MK	No. of teeth
5,600 - 8,899	150	84,5	88	65,5	1	4
8,900 - 9,899	160	94,5	98	65,5	1	6
9,900 - 12,899	170	104,5	108	65,5	1	6
12,900 - 15,899	180	114,5	118	65,5	1	6
15,900 - 16,899	200	120	125	80	2	6
16,900 - 18,899	210	130	135	80	2	6
18,900 - 21,599	220	140	145	80	2	6

- Recommended cutting data page 76 - 79
- Larger diameters on request
- Short delivery times for other length dimensions
- Retipping possible
- Coated version on request

Suitable for the following bores

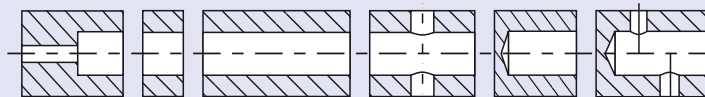

Order example:

Article no.  
2361 HM

Bore ø  
18

Bore tolerance  
H7

Bevel lead geometry  
G01



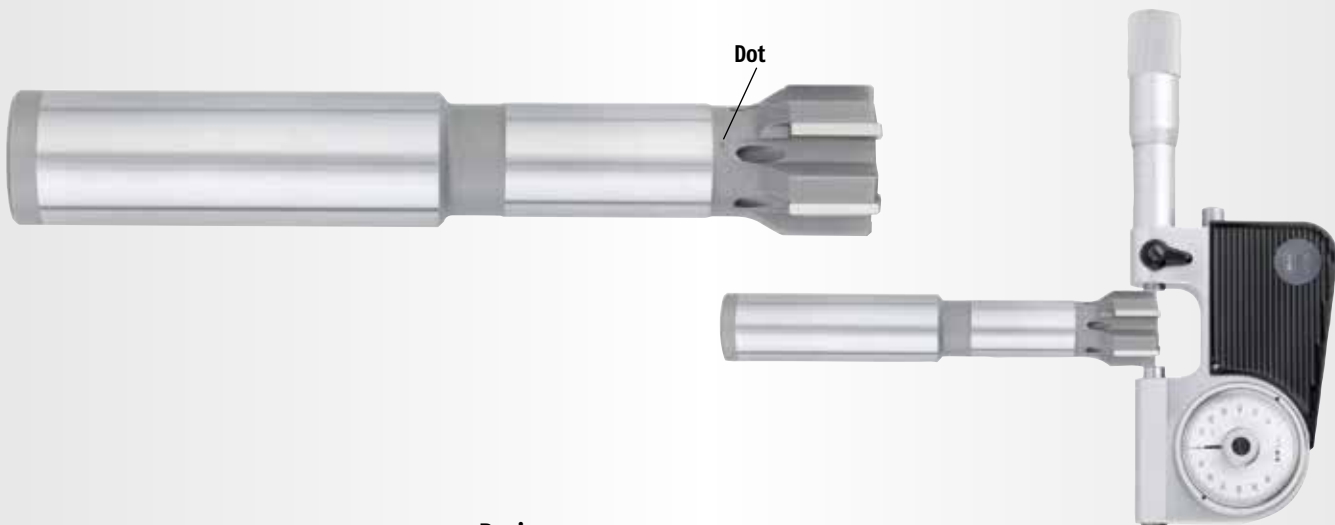

### Basics:

When delivered, all monoblock reamers are ground to the nominal bore diameter and tolerance.

Solid reamers = 2/3 tolerance

Expandable reamers = 1/2 tolerance

We recommend to measure the bore and only if it's necessary the reamer.

### Measurement:

The diameter of the reamer can be checked with any commercially available micrometer. The two blades to be measured are 180° opposite and marked with a dot. The reamer must be measured up front because of the back-taper. Be careful to not damage the bevel-lead edge.

### Expansion:

The conical screw has to be turned carefully clock-wise with the key until the required diameter is reached. About 30° or 5 minutes from a clock represent an expansion of about 6 - 12 microns mm depending on diameter.

This manipulation is meant to be for wear compensation only. Should the reamer be over expanded accidentally, loosen the conical screw completely and adjust again.

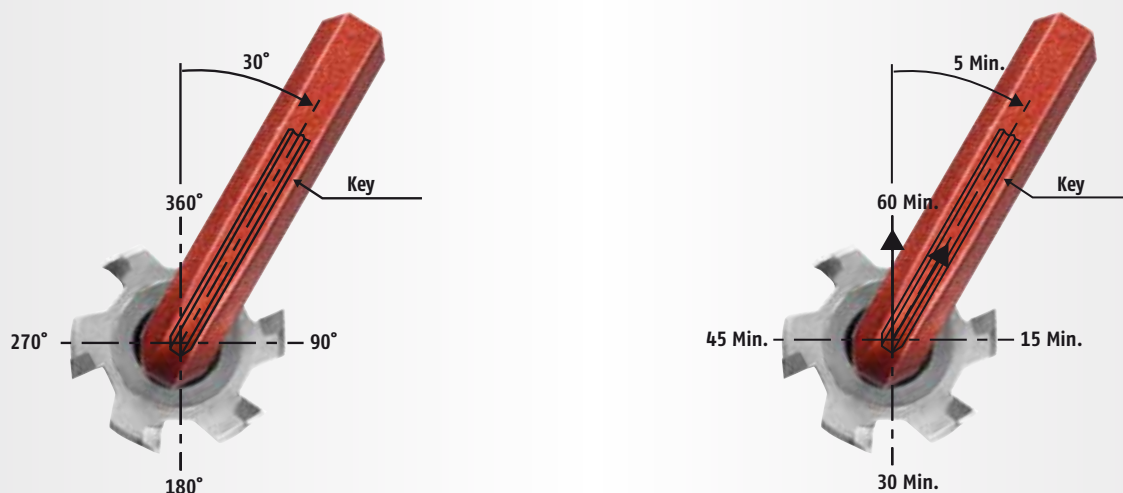



## Reaming Heads

### Product Features:

- Modular Reaming heads  $\varnothing$  9,600 – 60,000 mm
- Different cutting materials and coatings
- Simple, fast and precise interchangeability
- Holders with internal coolant supply
- Short and long holder version

### Product Advantages:

- Only 8 holders for a diameter range of 9,600 – 60,000 mm
- All Reaming heads are ground to the nominal size, e.g. first bore = good bore!
- Modular reaming system without diameter setting
- Short machining times thanks to high feeds and multi-blade design
- High economic efficiency thanks to repeated retippings
- Repaired/retipped Reaming heads have the same tool life as new reamers

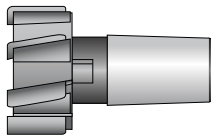
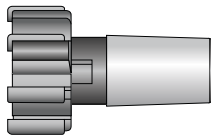
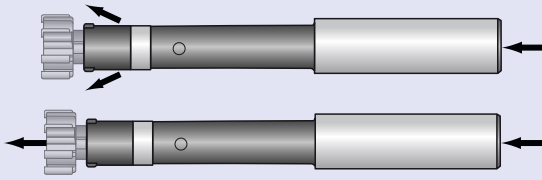
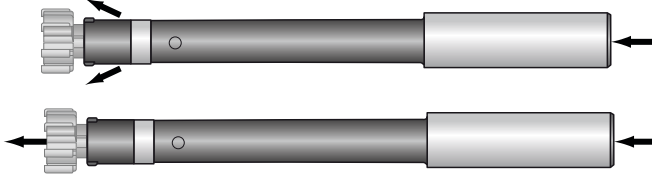

Type	Ø range mm			Page
340	9,600 - 60,000			20
540660 640660	9,600 - 60,000			21
540360 640360	9,600 - 60,000			22
Spare parts				23
Handling instructions				24 - 25

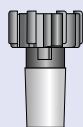

Reaming  
Heads

## Reaming Head, solid Left hand and straight fluted

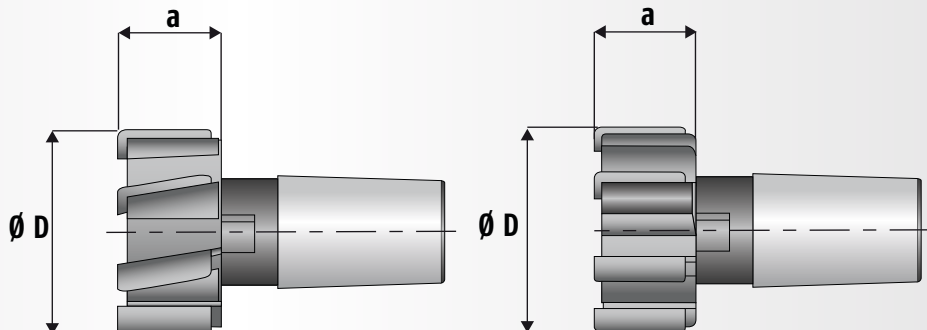

Type 340 Left hand fluted		Type 340 Straight fluted	
HM (Carbide)	CT (CERMET)	HM (Carbide)	CT (CERMET)
34020	34092	34021	34093
34070 TiN	34066 TiAlN	34071 TiN	34067 TiAlN
34037 TiAlN	34066P TiAlN-P	34038 TiAlN	34067P TiAlN-P
34037P TiAlN-P	34092 ATN	34038P TiAlN-P	34093 ATN
34037L TiAlN-L		34038L TiAlN-L	
34020 ATN		34021 ATN	
34020 ATC		34021 ATC	
34020 ZCN		34021 ZCN	

Bevel lead geometry see page 74  
Coating recommendations see page 78 - 79  
PCD on request

Ø D mm	Type 340 Left hand fluted		Type 340 Straight fluted	
	a mm	No. of teeth	a mm	No. of teeth
9,600 - 12,599	9,0	4	13,0	4
12,600 - 15,599	11,0	4	13,5	4
15,600 - 18,599	11,0	4	14,0	6
18,600 - 21,309	11,0	6	14,0	6
21,310 - 24,009	11,0	6	16,0	6
24,010 - 30,109	13,0	6	18,5	6
30,110 - 40,009	16,0	6	18,5	6
40,010 - 50,709	18,5	6	18,5	6
50,710 - 60,000	18,5	6	18,5	6

- Recommended cutting data page 76 - 79
- Handling instructions page 24 - 25
- Mountable on all reaming head holders
- Retipping and recoating possible

Order example:	Article no.	Bore ø	Bore tolerance	Bevel lead geometry
	34070 TiN	18	H7	G05

# Type 540660, 640660



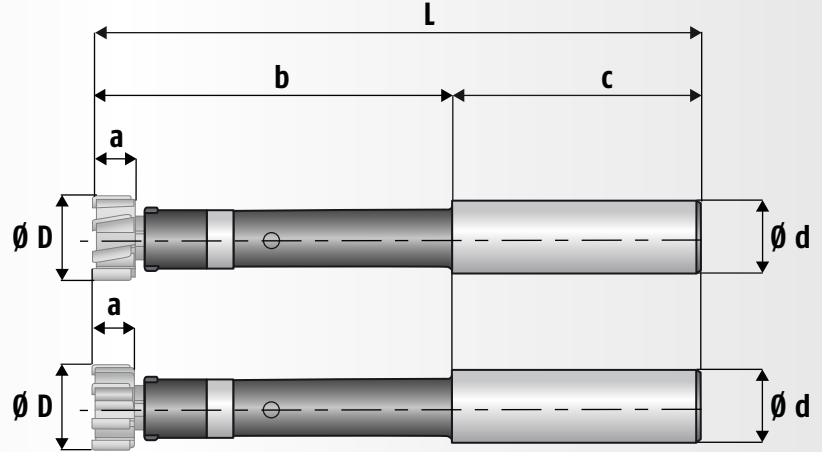

The reamer specialist

**Reaming Head Holder, short**  
 With internal coolant supply for through holes  
 or blind holes

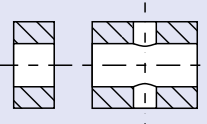
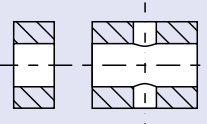
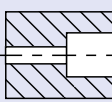
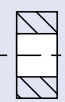

Article No.	Artikel Nr. Article No.	Ø D mm	Type 340 Left hand fluted			Type 340 Straight fluted			c mm	Ø d mm (h6)
			~ L mm	~ b mm	a mm	~ L mm	~ b mm	a mm		
540660000	640660000	9,600 - 12,599	88	48	9,0	92	52	13,0	40	12
540660001	640660001	12,600 - 15,599	99,5	59,5	11,0	102	62	13,5	40	16
540660002	640660002	15,600 - 18,599	110	60	11,0	113	63	14,0	50	20
540660003	640660003	18,600 - 21,309	130	80	11,0	133	83	14,0	50	20
		21,310 - 24,009	130	80	11,0	135	85	16,0	50	20
540660004	640660004	24,010 - 30,109	160,5	100,5	13,0	166	106	18,5	60	25
540660005	640660005	30,110 - 40,009	163,5	103,5	16,0	166	106	18,5	60	25
540660006	640660006	40,010 - 50,709	186	106	18,5	186	106	18,5	80	32
540660007	640660007	50,710 - 60,000	190	110	18,5	190	110	18,5	80	32

- Smaller shank diameters are possible
- Clamping flats to customer specification
- Handling instructions page 24 - 25
- Spare parts page 23

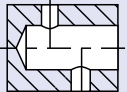
Suitable for the following bores	Type 340 Left hand fluted		Type 340 Straight fluted			
						
						

Order: Complete holder, Reaming head must be ordered separately

# Type 540360, 640360

The reamer specialist

**Reaming Head Holder, long**  
 With internal coolant supply for through holes  
 or blind holes

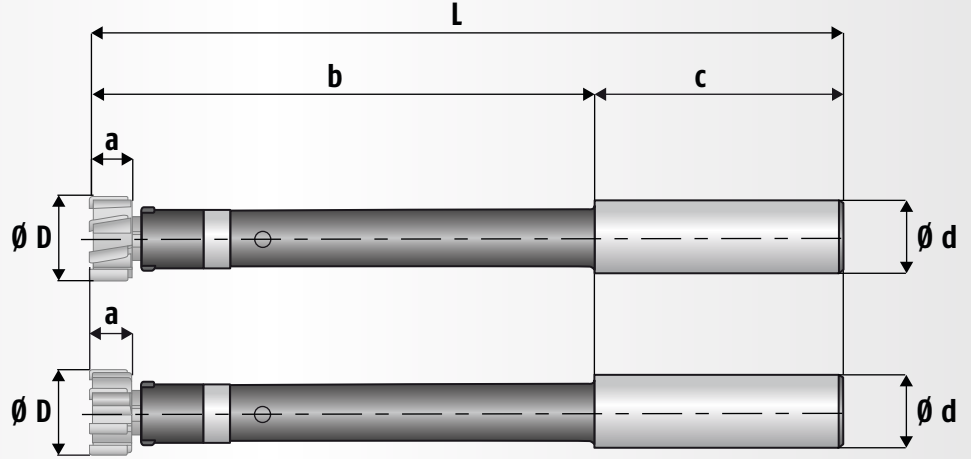

Article No.	Article No.	Ø D mm	Type 340 Left hand fluted			Type 340 Straight fluted			c mm	Ø d mm (h6)
			~ L mm	~ b mm	a mm	~ L mm	~ b mm	a mm		
540360000	640360000	9,600 - 12,599	151	111	9,0	155	115	13,0	40	12
540360001	640360001	12,600 - 15,599	152,5	112,5	11,0	155	115	13,5	40	16
540360002	640360002	15,600 - 18,599	171	121	11,0	174	124	14,0	50	20
540360003	640360003	18,600 - 21,309	191	141	11,0	194	144	14,0	50	20
		21,310 - 24,009	191	141	11,0	196	146	16,0	50	20
540360004	640360004	24,010 - 30,109	221,5	161,5	13,0	227	167	18,5	60	25
540360005	640360005	30,110 - 40,009	224,5	164,5	16,0	227	167	18,5	60	25
540360006	640360006	40,010 - 50,709	285	205	18,5	285	205	18,5	80	32
540360007	640360007	50,710 - 60,000	290	210	18,5	290	210	18,5	80	32

- Smaller shank diameters are possible
- Clamping flats to customer specification
- Handling instructions page 24 - 25
- Spare parts page 23

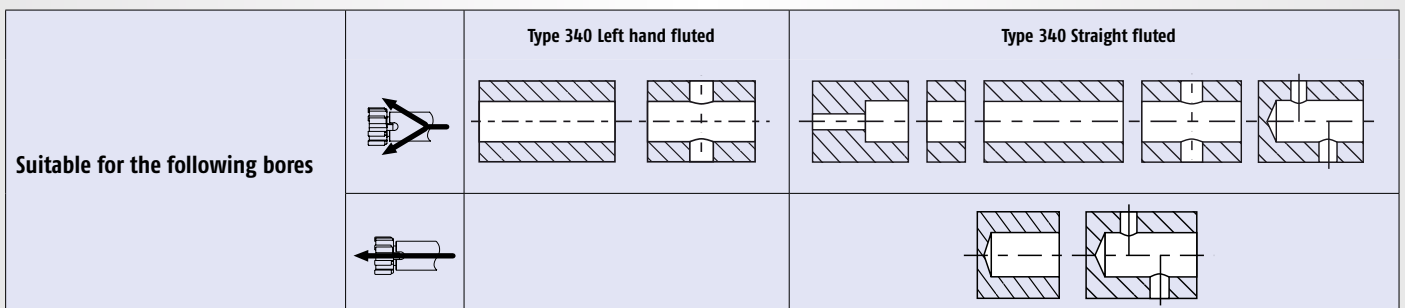

Order: Complete holder, Reaming head must be ordered separately

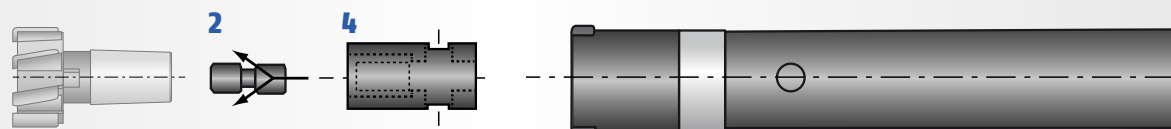

Type 340 Left hand fluted

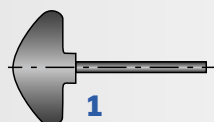

1

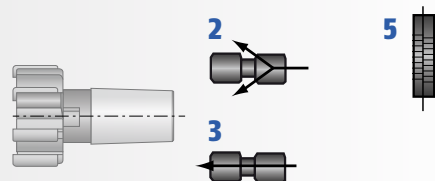



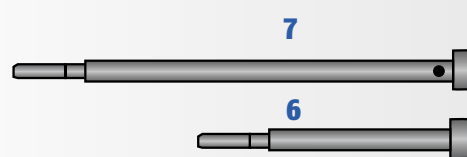



Type 340 Straight fluted



7

6

∅ D mm	Key	Left-/right-hand threaded screw		Bush	Pin	Screw	
							
	1	2	3	4	5	6	7
9,600 - 12,599	-	-	-	-	-	540040001	540040002
12,600 - 15,599	340350001	340150001	340830001	340330001	540030001	-	-
15,600 - 18,599	340350002	340150002	340830002	340330002	540030002	-	-
18,600 - 24,009	340350003	340150003	340830003	340330003	540030003	-	-
24,010 - 30,109	340350004	340150004	340830004	340330004	540030004	-	-
30,110 - 40,009	340350004	340150004	340830004	340330004	540030004	-	-
40,010 - 50,709	340350005	340150005	340830005	340330005	540030005	-	-
50,710 - 60,000	340350005	340150005	340830005	340330005	540030005	-	-

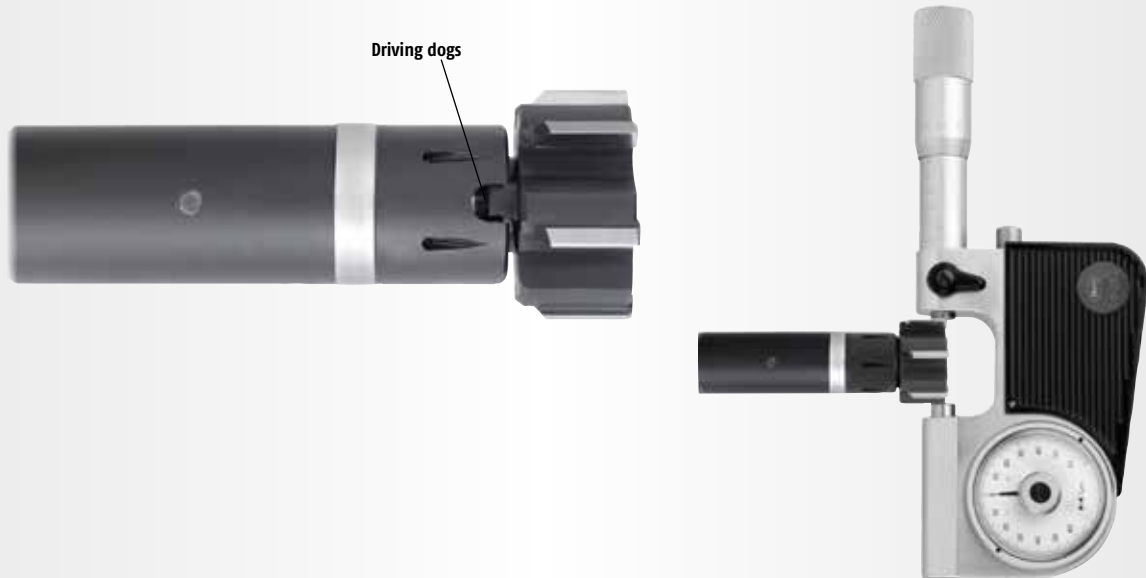

### Basics:

When delivered, all Reaming heads are ground to the nominal bore diameter and tolerance.

Solid Reaming heads = 2/3 tolerance

We recommend to measure the bore and only if it's necessary the Reaming head.

### Measurement:

The diameter of the Reaming head can be checked with any commercially available micrometer. The two blades to be measured are 180° opposite and marked with the driving dogs. The reamer must be measured up front because of the back-taper. Be careful to not damage the bevel-lead edge.





# Handling Instructions

The reamer specialist

1.	Thoroughly clean the parts. Clean taper in holder (1) thoroughly.															
2.	Lubricate the threaded pin (2) with copper grease and screw it 1½ turns into the Reaming head (3) (left hand thread)															
3.	Lightly grease the taper of the Reaming head (3).															
4.	Place the Reaming head (3) with the mounted LH/RH (2) screw into the holder (1).															
5.	Fasten the Reaming head (1) with the special key (4). After one turn of the key, the screw must have engaged in the holder thread. At the same time hold the Reaming head in place and avoid its turning.															
6.	<p>The driving dogs of the Reaming head (3) must lie in the shoulder slot of the holder against the direction of rotation.</p> <table border="1" data-bbox="172 1585 501 1883"> <thead> <tr> <th>∅ Range mm</th> <th>Tightening torque M Nm</th> </tr> </thead> <tbody> <tr> <td>9,600 - 12,599</td> <td>*</td> </tr> <tr> <td>12,600 - 15,599</td> <td>0,65 - 0,95</td> </tr> <tr> <td>15,600 - 18,599</td> <td>1,05 - 1,45</td> </tr> <tr> <td>18,600 - 24,009</td> <td>1,75 - 2,35</td> </tr> <tr> <td>24,010 - 40,009</td> <td>2,95 - 3,85</td> </tr> <tr> <td>40,010 - 60,000</td> <td>5,15 - 6,65</td> </tr> </tbody> </table>	∅ Range mm	Tightening torque M Nm	9,600 - 12,599	*	12,600 - 15,599	0,65 - 0,95	15,600 - 18,599	1,05 - 1,45	18,600 - 24,009	1,75 - 2,35	24,010 - 40,009	2,95 - 3,85	40,010 - 60,000	5,15 - 6,65	
∅ Range mm	Tightening torque M Nm															
9,600 - 12,599	*															
12,600 - 15,599	0,65 - 0,95															
15,600 - 18,599	1,05 - 1,45															
18,600 - 24,009	1,75 - 2,35															
24,010 - 40,009	2,95 - 3,85															
40,010 - 60,000	5,15 - 6,65															

\*Attention: Reaming heads (3) up to diameter 12,599 mm are assembled with a clamping screw from the back of the holder. The screw has a counter clockwise thread.



## Cutting Rings

### Product Features:

- Modular Cutting rings  $\varnothing$  50,600 – 205,599 mm
- Expandable, straight fluted
- Different cutting materials and coatings
- Simple and precise interchangeability
- Holders with internal coolant supply
- Short and long holder version

### Product Advantages:

- Only 16 holders sizes for a diameter range of 50,600 – 205,599 mm
- All mounted Cutting rings are ground to the nominal size, e.g. first bore = good bore!
- Short machining times thanks to high feeds and multi-blade design
- Wear compensation through the simple expansion feature.
- High economic efficiency thanks to repeated retippings
- Repaired / retipped Cutting rings have the same tool life as new reamers

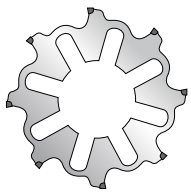
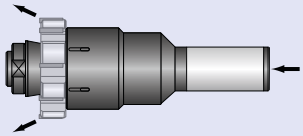
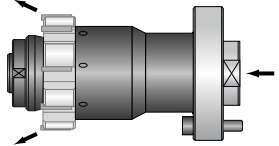
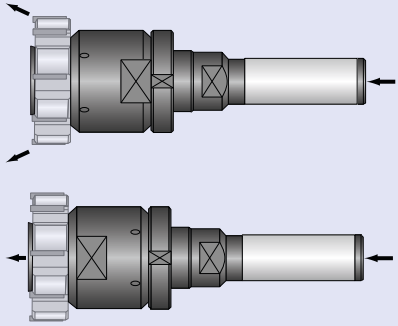
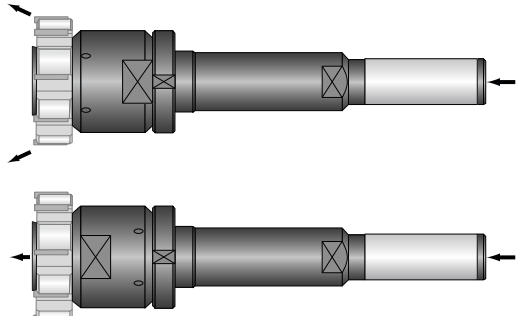

Type	∅ range mm		Page
300	50,600 - 205,599		28
50376	50,600 - 100,599		29
50776	50,600 - 205,599		30
51376 51381	50,600 - 165,599		31
51476 51481	50,600 - 165,599		32
Spare parts			33 - 34
Handling instructions			35 - 37

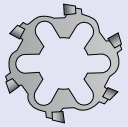

Cutting Rings



## Cutting Ring Straight fluted

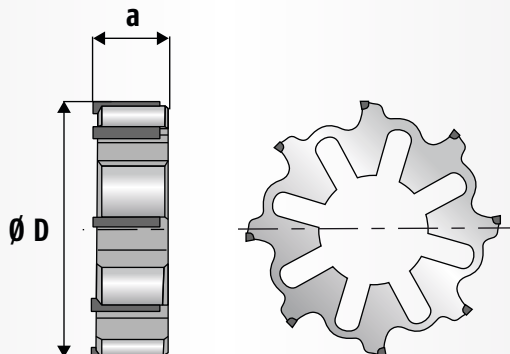

Type 300 Expandable	
HM (Carbide)	CT (CERMET)
30025	30045
30005 TiN	30008 TiAlN
30007 TiAlN	30008P TiAlN-P
30007P TiAlN-P	30045 ATN
30007L TiAlN-L	
30025 ATN	
30025 ATC	
30025 ZCN	

Bevel lead geometry see page 74  
Coating recommendations see page 76 - 77  
PCD on request

Ø D mm	a mm	No. of teeth
50,600 - 79,599	18,5	6
79,600 - 100,599	18,5	8
100,600 - 110,599	18,5	10
110,600 - 205,599	18,5	12

- Recommended cutting data page 76 - 79
- Handling instructions page 35 - 37
- Mountable on all cutting ring holders
- Retipping and recoating possible

Order example:	Article no.	Bore ø	Bore tolerance	Bevel lead geometry
	30025ATC	100	H7	G01



# Type 50376

The reamer specialist

## Cutting Ring Holder

With internal coolant supply for through holes

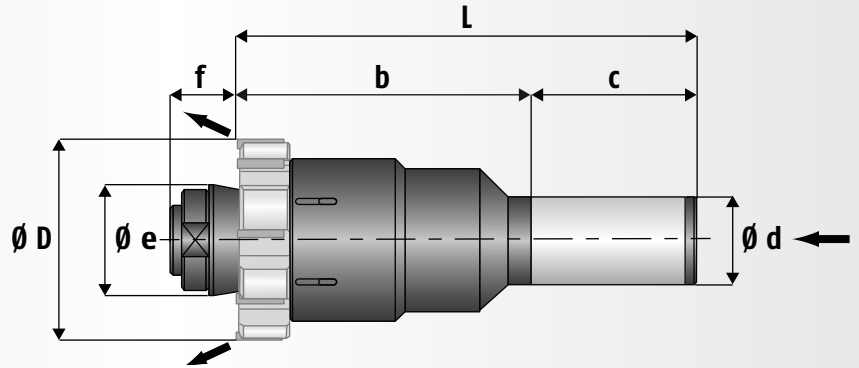

Article No.	$\varnothing D$ mm	L mm	b mm	c mm	$\varnothing e$ mm	f mm	$\varnothing d$ mm (h6)
50376.008	50,600 - 60,599	165	105	60	30,3	22,5	32
50376.009	60,600 - 70,599	165	105	60	40,0	24,5	32
50376.010	70,600 - 79,599	165	105	60	40,0	24,5	32
50376.011	79,600 - 90,599	175	115	60	56,2	28,5	32
50376.012	90,600 - 100,599	175	115	60	56,2	28,5	32

- Clamping flats to customer specification
- Handling instructions page 35 - 36
- Spare parts page 34

Suitable for the following bores

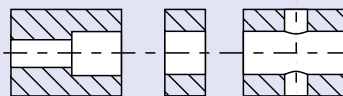

Order: Complete holder, cutting ring must be ordered separately.



# Type 50776

The reamer specialist

## Cutting Ring Holder

With module-flange for compensation holders

With internal coolant supply for through holes

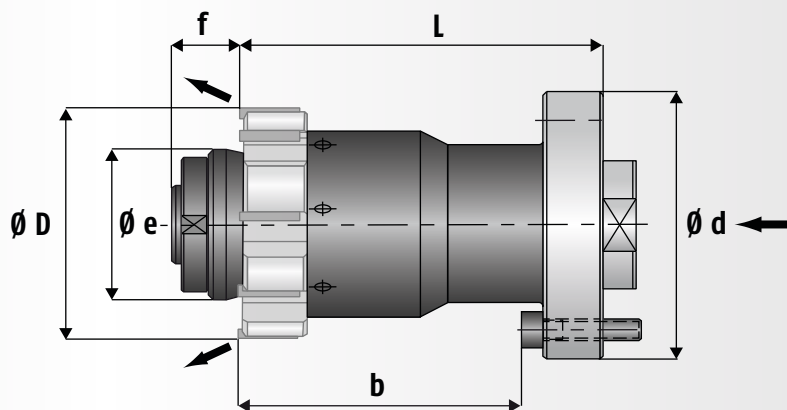

Article No.	$\varnothing D$ mm	L mm	b mm	$\varnothing e$ mm	f mm	Module $\varnothing$ mm
50776.008	50,600 - 60,599	118	89	30,3	22,5	100
50776.009	60,600 - 70,599	126	97	40,0	24,5	100
50776.010	70,600 - 79,599	126	97	40,0	24,5	100
50776.011	79,600 - 90,599	126	97	56,2	28,5	100
50776.012	90,600 - 100,599	126	97	56,2	28,5	100
50776.013	100,600 - 110,599	157		73,4	35,5	100
50776.014	110,600 - 115,599	157		80,4	35,5	100
50776.015	115,600 - 125,599	157		86,4	35,5	100
50776.016	125,600 - 132,599	157		90,4	35,5	100
50776.017	132,600 - 139,599	157		90,4	35,5	100
50776.018	139,600 - 145,599	157		101,1	35,5	100
50776.019	145,600 - 155,599	157		107,1	35,5	100
50776.020	155,600 - 165,599	157		107,4	49,5	100
50776.021	165,600 - 175,599	157		117,4	49,5	100
50776.022	175,600 - 185,599	157		127,4	49,5	100
50776.023	185,600 - 195,599	157		137,0	49,5	100
50776.024	195,600 - 205,599	157		145,4	49,5	100

- Compensation holder page 54 - 57
- Handling instructions page 35 - 36
- Spare parts page 34

Suitable for the following bores

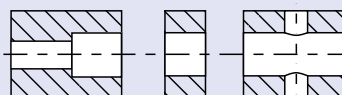

Order: Complete holder, cutting ring must be ordered separately.





# Type 51376, 51381

The reamer specialist

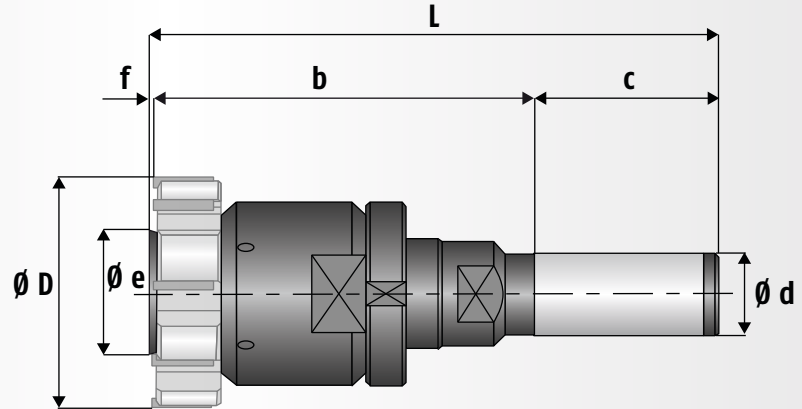

## Cutting Ring Holder, short

With internal coolant supply for through holes or blind holes

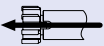

		Ø D mm	L mm	b mm	c mm	Ø e mm	f mm	Ø d mm (h6)
51376.008	51381.008	50,600 - 60,599	166,5	105	60	27,8	1,5	20
51376.009	51381.009	60,600 - 70,599	166,5	105	60	37,0	1,5	25
51376.010	51381.010	70,600 - 79,599	166,5	105	60	37,0	1,5	25
51376.011	51381.011	79,600 - 90,599	166,5	105	60	53,2	1,5	32
51376.012	51381.012	90,600 - 100,599	166,5	105	60	53,2	1,5	32
51376.013	51381.013	100,600 - 110,599	166,5	105	60	70,4	1,5	32
51376.014	51381.014	110,600 - 115,599	166,5	105	60	77,4	1,5	32
51376.015	51381.015	115,600 - 125,599	166,5	105	60	83,4	1,5	32
51376.016	51381.016	125,600 - 132,599	166,5	105	60	87,4	1,5	32
51376.017	51381.017	132,600 - 139,599	166,5	105	60	87,4	1,5	32
51376.018	51381.018	139,600 - 145,599	166,5	105	60	99,4	1,5	32
51376.019	51381.019	145,600 - 165,599	166,5	105	60	104,4	1,5	32

- Clamping flats to customer specification
- Handling instructions page 35, 37
- Spare parts page 33

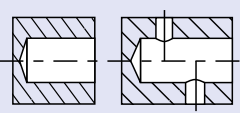
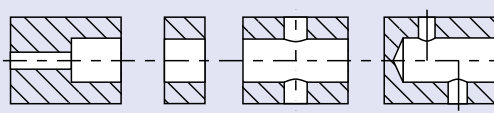
		
Suitable for the following bores		

Order: Complete holder, cutting ring must be ordered separately.





# Type 51476, 51481

The reamer specialist

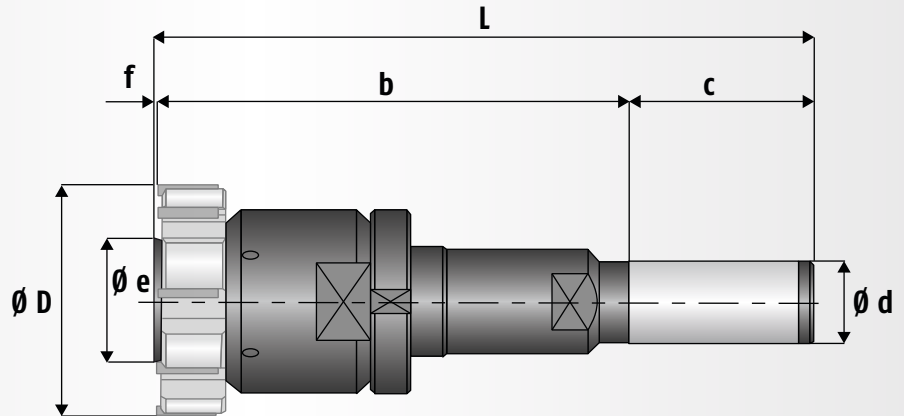

## Cutting Ring Holder, long

With internal coolant supply for through holes or blind holes



		$\varnothing D$ mm	L mm	b mm	c mm	$\varnothing e$ mm	f mm	$\varnothing d$ mm (h6)
51476.008	51481.008	50,600 - 60,599	275,5	214	60	27,8	1,5	20
51476.009	51481.009	60,600 - 70,599	298,5	237	60	37,0	1,5	25
51476.010	51481.010	70,600 - 79,599	298,5	237	60	37,0	1,5	25
51476.011	51481.011	79,600 - 90,599	301,5	240	60	53,2	1,5	32
51476.012	51481.012	90,600 - 100,599	301,5	240	60	53,2	1,5	32
51476.013	51481.013	100,600 - 110,599	301,5	240	60	70,4	1,5	32
51476.014	51481.014	110,600 - 115,599	301,5	240	60	77,4	1,5	32
51476.015	51481.015	115,600 - 125,599	301,5	240	60	83,4	1,5	32
51476.016	51481.016	125,600 - 132,599	301,5	240	60	87,4	1,5	32
51476.017	51481.017	132,600 - 139,599	301,5	240	60	87,4	1,5	32
51476.018	51481.018	139,600 - 145,599	301,5	240	60	99,4	1,5	32
51476.019	51481.019	145,600 - 165,599	301,5	240	60	104,4	1,5	32

- Clamping flats to customer specification
- Handling instructions page 35, 37
- Spare parts page 33

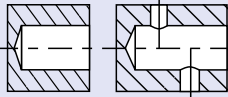
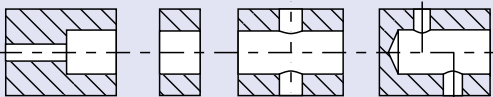
		
Suitable for the following bores		

Order: Complete holder, cutting ring must be ordered separately.





For cutting ring holders type: 51376, 51381, 51481, 51476

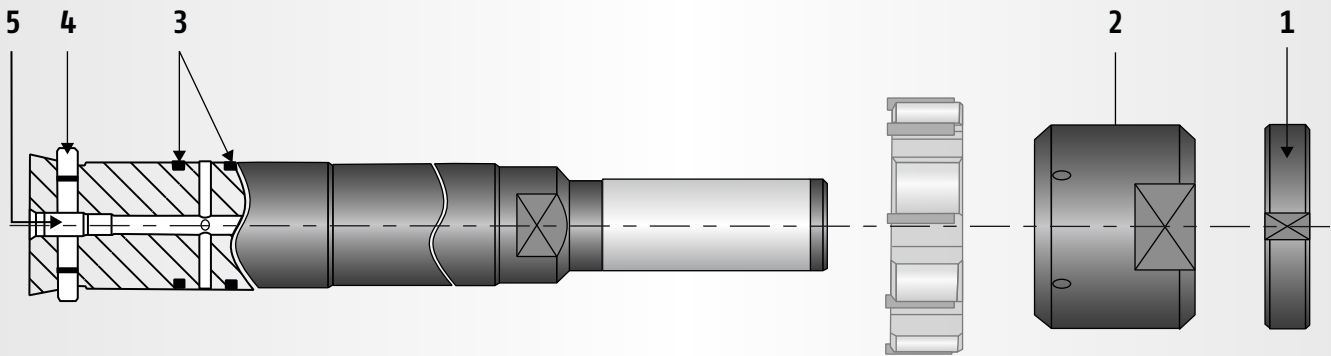

Ø D mm	1 Expansion nut	2 Bush	3* O-ring	4 Drive pin	5* Threaded pin
50,600 - 60,599	35023001	51015007	Ø 22 X 2	35014002	M6 x 12 09910520-1
60,600 - 70,599	35023002	51015008	Ø 30 X 2	35014002	M6 x 12 09910520-1
70,600 - 79,599	35023002	51015009	Ø 30 X 2	35014002	M6 x 12 09910520-1
79,600 - 90,599	35023003	51015010	Ø 45 X 3	35014003	M10 x 20 09910520-2
90,600 - 100,599	35023003	51015011	Ø 45 X 3	35014003	M10 x 20 09910520-2
100,600 - 110,599	35023003	51015012	Ø 45 X 3	35014003	M10 x 20 09910520-2
110,600 - 115,599	35023003	51015013	Ø 45 X 3	35014003	M10 x 20 09910520-2
115,600 - 125,599	35023003	51015014	Ø 45 X 3	35014003	M10 x 20 09910520-2
125,600 - 132,599	35023003	51015015	Ø 45 X 3	35014003	M10 x 20 09910520-2
132,600 - 139,599	35023003	51015016	Ø 45 X 3	35014003	M10 x 20 09910520-2
139,600 - 145,599	35023003	51015017	Ø 45 X 3	35014003	M10 x 20 09910520-2
145,600 - 150,599	35023003	51015018	Ø 45 X 3	35014003	M10 x 20 09910520-2

\* For holder type 51376, 51476

\* Item 3 only supplied for application where MQL is required



For cutting ring holders type: 50376, 50776

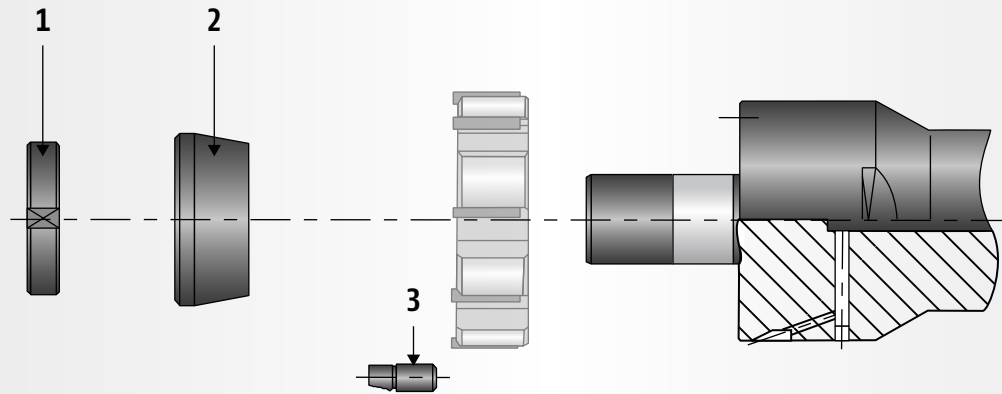

Ø D mm	1 Expansion nut	2 Conical ring	3 Drive pin
50,600 - 60,599	09900088	30180005	30030006
60,600 - 70,599	09900090	30180006	30030007
70,600 - 79,599	09900090	30180006	30030007
79,600 - 90,599	09900092	30180007	30030008
90,600 - 100,599	09900092	30180007	30030008
100,600 - 110,599	09900095	30620001	30030008
110,600 - 115,599	09900095	30620002	30030008
115,600 - 120,599	09900095	30620003	30030008
120,600 - 125,599	09900095	30620003	30030008
125,600 - 132,599	09900095	30620004	30030009
132,600 - 139,599	09900095	30620004	30030009
139,600 - 145,599	09900095	30620005	30030009
145,600 - 155,599	09900095	30620006	30030010
155,600 - 165,599	09900102	30620007	30030010
165,600 - 175,599	09900102	30620008	30030010
175,600 - 185,599	09900102	30620009	30030010
185,600 - 195,599	09900102	30620010	30030010
195,600 - 200,599	09900102	30620011	30030010

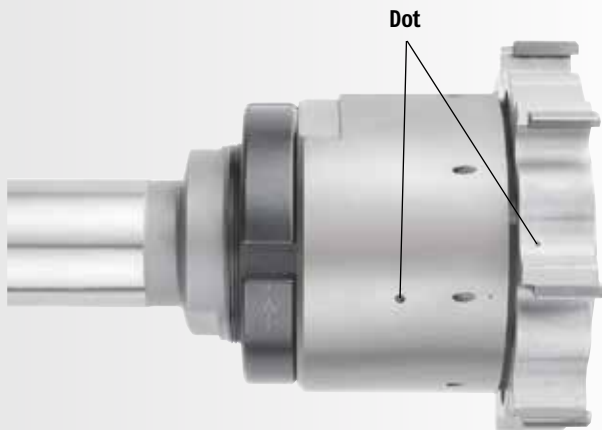

## Basics:

When delivered, all Cutting rings are ground to the nominal bore diameter and tolerance.

Expandable Cutting rings = 1/2 tolerance

We recommend to measure the bore and only if it's necessary the cutting ring.

Loose, not mounted Cutting rings should not be measured.

## Measurement:



The diameter of the cutting ring can be checked with any commercially available micrometer. The two blades to be measured are 180° opposite and marked with a dot. The reamer must be measured up front because of the back-taper. Be careful to not damage the bevel-lead edge.



# Handling Instructions

The reamer specialist

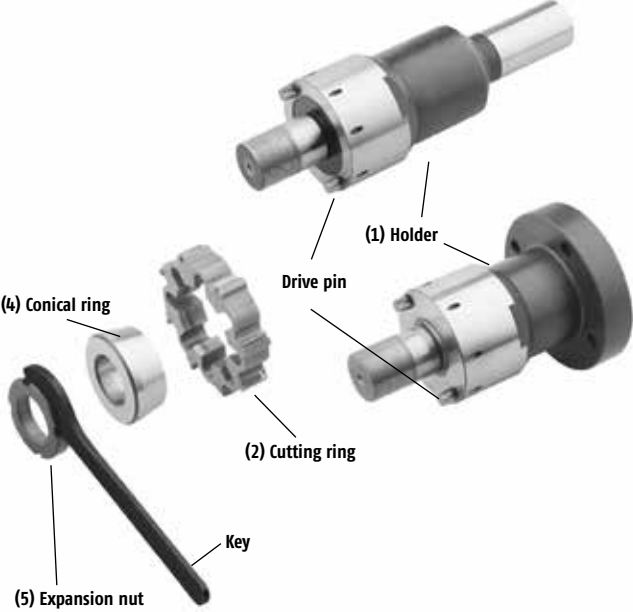
Type 50376, 50776

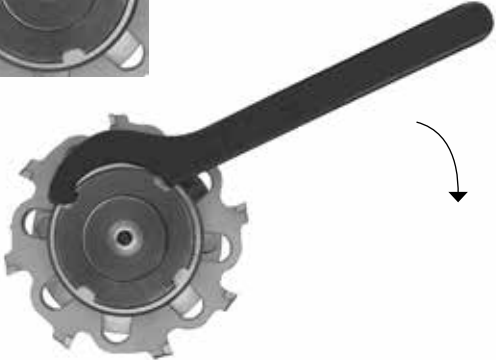
<p>1. Clean all parts carefully and copper grease thread on holder (1) lightly.</p>	
<p>2. Slip the cutting ring (2) onto the holder (1) up to the taper (Bevel lead of the cutting edge to the front). The dotting mark of the holder (1) and the dotting mark on the cutting ring (2) must have the same position. See picture page 35.</p>	
<p>3. Slide the conical ring (4) onto the holder.</p>	
<p>4. Tighten the expansion nut slightly by hand in the direction of the arrow (check symbol on nut).</p>	
<p>5. The coolant hole which is next to the dotting mark on the holder (1) must be directed to the chip room / cutting edge of the cutting ring (2).</p>	
<p>6. Before tightening the expansion nut (5) press the driving pins to the cutting ring (2) against the direction of rotation.</p>	
<p>7. Tighten the expansion nut (5) until you reach the middle of the diameter tolerance.</p>	

**Important:** We recommend to set the expandable Cutting rings to the middle of the tolerance.



# Handling Instructions

The reamer specialist

Type 51376, 51476, 51381, 51481

<p>1. Clean all parts carefully.</p>		
<p>2. Slip the cutting ring (2) onto the holder (1) up to the taper. The driving pin of the holder (1) and the dotting mark on the cutting ring (2) must have the same position.</p>	<p>*For MQL application only</p>	
<p>3. <b>For MQL application only:</b> Fit the O-rings (3) into the two grooves.</p>		
<p>4. Then slip the bush (4) and the expansion nut (5) onto the holder and tighten lightly.</p>		
<p>5. The coolant hole which is next to the dotting mark on the bush (4) must be directed to the chip room/cutting edge of the cutting ring (2).</p>	<p>Type 51376 51476</p>	<p>Type 51381 51481</p>
<p>6. Before tightening the expansion nut (5) press the driving pins to the cutting ring (2) against the direction of rotation.</p>		
<p>7. Tighten the expansion nut (5) until you reach the middle of the diameter tolerance.</p>		

Important: We recommend to set the expandable Cutting to the middle of the tolerance.

**NEW**

# Top Speed Ring

**DIATOOL®**

The reamer specialist



## Top Speed Ring

### Product Features:

- Modular Top Speed Rings from  $\varnothing$  50,600 –  $\varnothing$  225,000 mm
- Four (4) extra teeth compared to other reamer ring systems
- From  $\varnothing$  50,600 mm with Z=10 / from  $\varnothing$  79,600 mm with Z=12 / from  $\varnothing$  100,600 mm with Z=16
- Solid, straight fluted
- Different cutting materials and coatings
- Simple, fast and precise replaceable
- Holders with internal coolant supply
- Holders with cylindrical shanks or Module connections for run-out compensation

### Product Advantages:

- Up to 70% higher feed rates compared to standard cutting rings
- No size setting required
- Longer tool life compared to standard cutting rings
- Better roundness qualities achievable
- Better surface finish achievable
- Only 16 holder size for a diameter range of 50,600 – 225,000 mm
- Different special geometries are possible
- High economic efficiency thanks to repeated retippings
- Repaired / retipped Top Speed Rings have the same tool life as new reamers

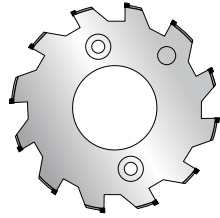
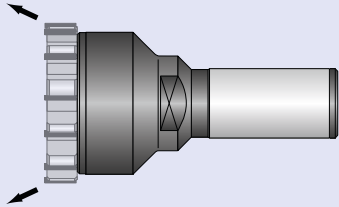
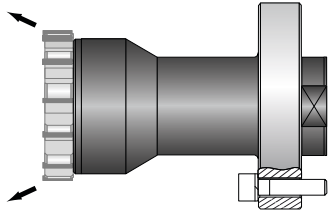

Type	ø range mm		Page
502	50,600 - 225,000		40
50313	50,600 - 100,599		41
50325	50,600 - 225,000		42
Spare parts			43 - 44
Handling instructions			45 - 46

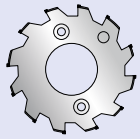

Top Speed Ring



## Top Speed Ring Straight fluted

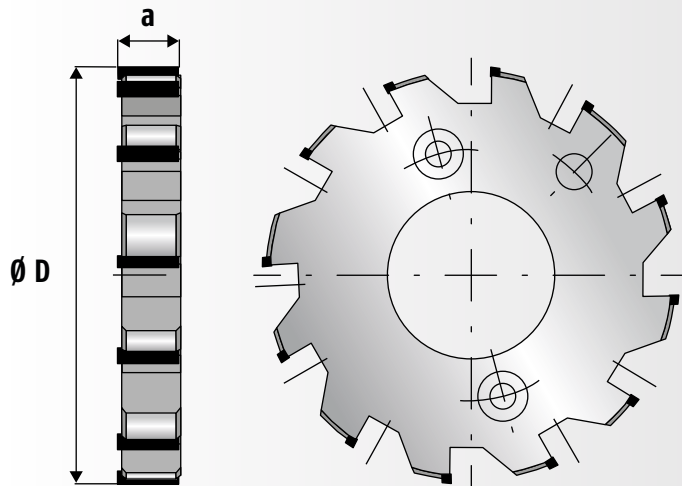

Type 502 Straight fluted	
HM (Carbide)	CT (CERMET)
50221	50293
50271 TiN	50267 TiAlN
50238 TiAlN	50267P TiAlN-P
50238P TiAlN-P	50293 ATN
50238L TiAlN-L	
50221 ATN	
50221 ATC	
50221 ZCN	

Bevel lead geometry see page 74  
Coating recommendations see page 76 - 77

Ø D mm	~ a mm	No. of teeth
50,600 - 79,599	15	10
79,600 - 100,599	15	12
100,600 - 225,000	17	16

- Recommended cutting data page 76 - 79
- Handling instructions page 45 - 46
- Retipping and recoating possible

Order example:	Article no.	Bore ø	Bore tolerance	Bevel lead geometry
	50271 TiN	60	H7	G01





# Type 50313

The reamer specialist

## Top Speed Ring Holder

With internal coolant supply for through holes and blind holes

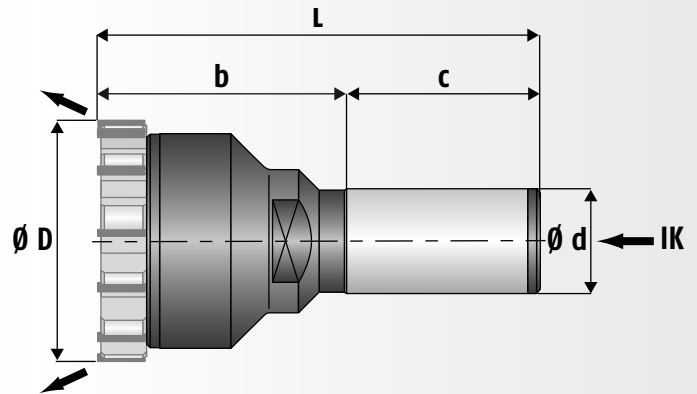

Article No.	Ø D mm	L mm	b mm	c mm	Ø e mm
50313.006	50.600 - 60.599	135	75	60	32
50313.007	60.600 - 70.599	135	75	60	32
50313.008	70.600 - 79.599	135	75	60	32
50313.009	79.600 - 90.599	135	75	60	32
50313.010	90.600 - 100.599	135	75	60	32

- Clamping flats to customer specification
- Handling instructions page 45 - 46
- Spare parts page 43

Suitable for the following bores

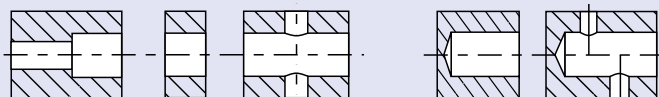

Order: Complete holder, Top Speed Ring must be ordered separately.



# Type 50325

The reamer specialist

## Top Speed Ring Holder

With module-flange for compensation holders

With internal coolant supply for through holes and blind holes

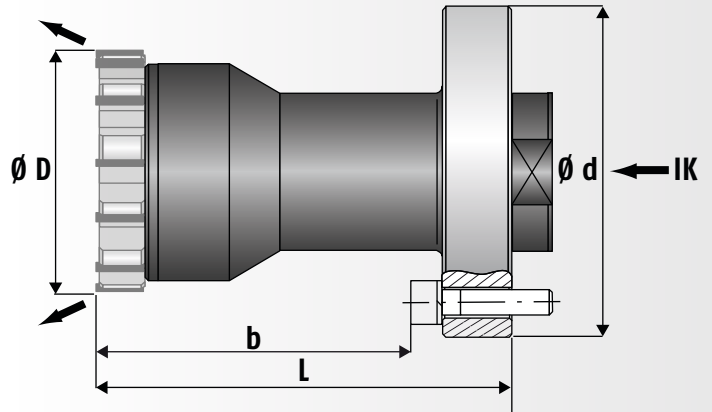

Article No.	$\varnothing D$ mm	L mm	b mm	Module $\varnothing$ mm
50325.006	50.600 - 60.599	118	89	100
50325.007	60.600 - 70.599	126	97	100
50325.008	70.600 - 79.599	126	97	100
50325.009	79.600 - 90.599	126	97	100
50325.010	90.600 - 100.599	126	97	100
50325.011	100.600 - 110.599	157		100
50325.012	110.600 - 120.599	157		100
50325.013	120.600 - 130.599	157		100
50325.014	130.600 - 140.599	157		100
50325.015	140.600 - 150.599	157		100
50325.016	150.600 - 160.599	157		100
50325.017	160.600 - 170.599	157		100
50325.018	170.600 - 180.599	157		100
50325.019	180.600 - 190.599	157		100
50325.020	190.600 - 205.599	157		100
50325.021	205.600 - 225.599	157		100

- Compensation holder page
- Handling instructions page 45 - 46
- Spare parts page 44

Suitable for the following bores

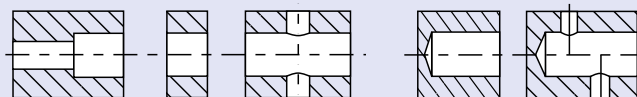

Order: Complete holder, Top Speed Ring must be ordered separately.



## For Top Speed Ring holders type: 51313

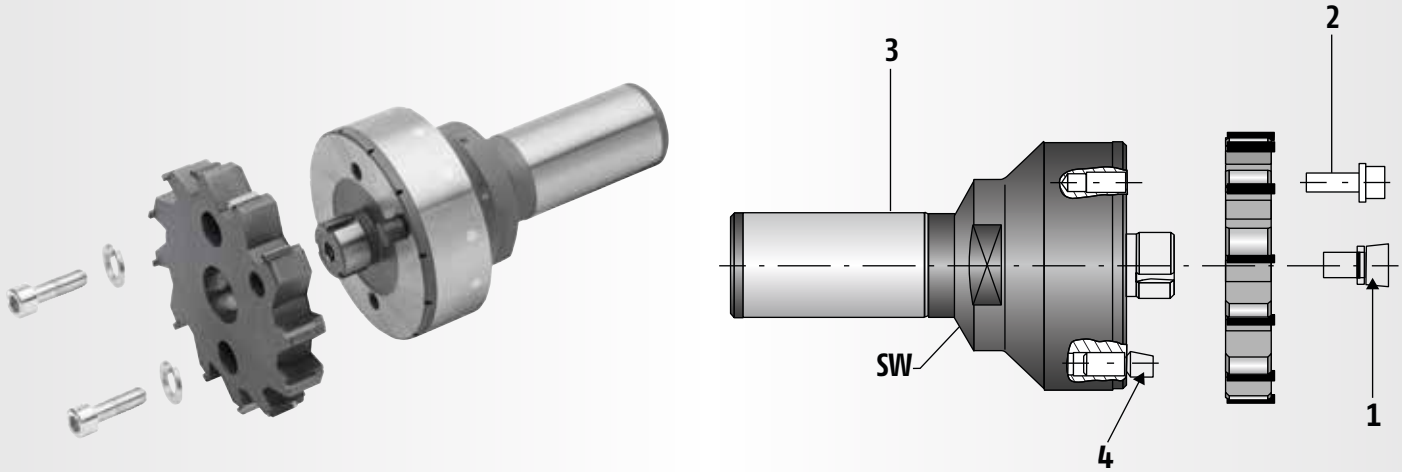

Article No.	No. of teeth	Ø D mm	1 Conical ring / Conical screw	2 Cylinder screw with spring ring	3 Holder	4 Pin
50313.006	10	50,600 - 60,599	51317001	DIN912 8.8 M4 x16 DIN128-A 4-Fst	50313.105	50318005
50313.007	10	60,600 - 70,599	51317001	DIN912 8.8 M4 x16 DIN128-A 4-Fst	50313.106	50318005
50313.008	10	70,600 - 79,599	51317002	DIN912 8.8 M6 x16 DIN128-A 6-Fst	50313.107	30030006
50313.009	12	79,600 - 90,599	51317002	DIN912 8.8 M6 x16 DIN128-A 6-Fst	50313.108	30030007
50313.010	12	90,600 - 100,599	51317003	DIN912 8.8 M6 x16 DIN128-A 6-Fst	50313.109	30030007



## For Top Speed Ring holders type: 51325

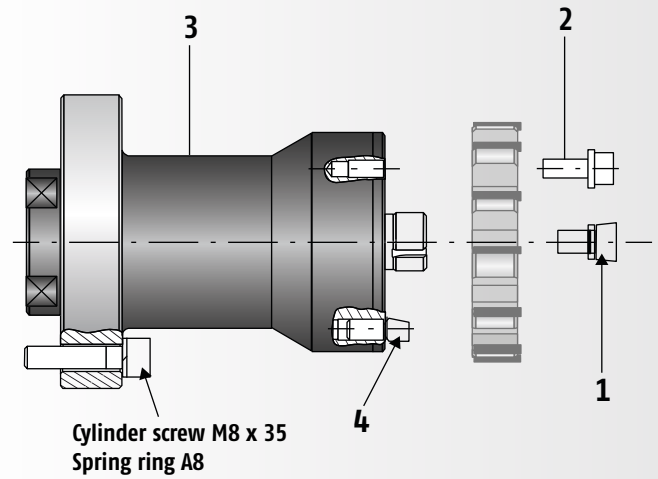
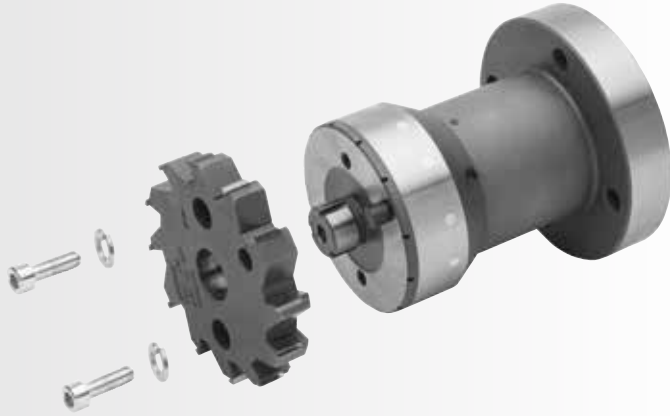

Article No.	No. of teeth	Ø D mm	1 Conical ring / Conical screw	2 Cylinder screw with spring ring	3 Holder	4 Pin
50325.006	10	50,600 - 60,599	51317001	DIN912 8.8 M4 x 16 DIN128-A 4-Fst	50325.105	50318005
50325.007	10	60,600 - 70,599	51317001	DIN912 8.8 M4 x 16 DIN128-A 4-Fst	50325.106	50318005
50325.008	10	70,600 - 79,599	51317002	DIN912 8.8 M6 x 16 DIN128-A 6-Fst	50325.107	30030006
50325.009	12	79,600 - 90,599	51317002	DIN912 8.8 M6 x 16 DIN128-A 6-Fst	50325.108	30030007
50325.010	12	90,600 - 100,599	51317003	DIN912 8.8 M6 x 16 DIN128-A 6-Fst	50325.109	30030007
50325.011	16	100,600 - 110,599	51317004	DIN912 8.8 M6 x 20 DIN128-A 6-Fst	50325.110	30030008
50325.012	16	110,600 - 120,599	51317004	DIN912 8.8 M6 x 20 DIN128-A 6-Fst	50325.111	30030008
50325.013	16	120,600 - 130,599	51317004	DIN912 8.8 M6 x 20 DIN128-A 6-Fst	50325.112	30030008
50325.014	16	130,600 - 140,599	51317004	DIN912 8.8 M6 x 20 DIN128-A 6-Fst	50325.113	30030008
50325.015	16	140,600 - 150,599	51317004	DIN912 8.8 M6 x 20 DIN128-A 6-Fst	50325.114	30030008
50325.016	16	150,600 - 160,599	51317004	DIN912 8.8 M6 x 20 DIN128-A 6-Fst	50325.115	30030008
50325.017	16	160,600 - 170,599	51317004	DIN912 8.8 M6 x 20 DIN128-A 6-Fst	50325.116	30030008
50325.018	16	170,600 - 180,599	51317004	DIN912 8.8 M6 x 20 DIN128-A 6-Fst	50325.117	30030008
50325.019	16	180,600 - 190,599	51317004	DIN912 8.8 M6 x 20 DIN128-A 6-Fst	50325.118	30030008
50325.020	16	190,600 - 205,599	51317004	DIN912 8.8 M8 x 20 DIN128-A 8-Fst	50325.119	30030009
50325.021	16	205,600 - 225,599	51317004	DIN912 8.8 M8 x 20 DIN128-A 8-Fst	50325.120	30030009

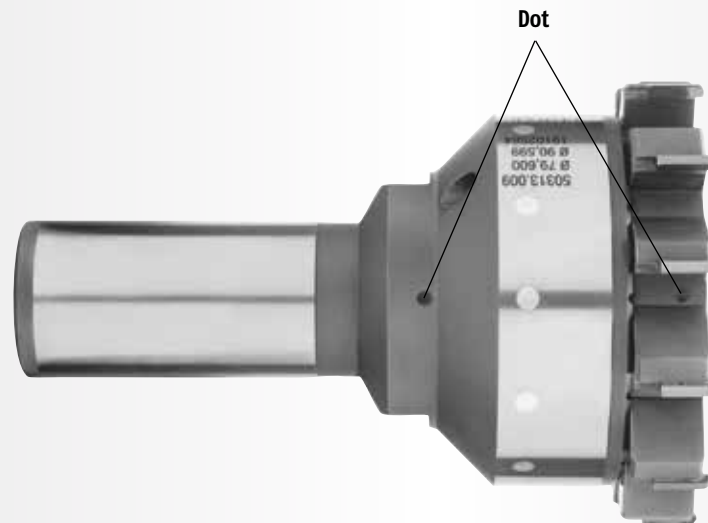

### Basics:

When delivered, all Top Speed Rings are ground to the nominal bore diameter and tolerance.

Top Speed Rings = 2/3 tolerance

We recommend to measure the bore and only if it's necessary the Top Speed Ring.

### Measurement:



The diameter of the Top Speed Ring can be checked with any commercially available micrometer. The two blades to be measured are 180° opposite and marked with a dot. The reamer must be measured up front because of the back-taper. Be careful to not damage the bevel-lead edge.



# Handling Instructions

The reamer specialist

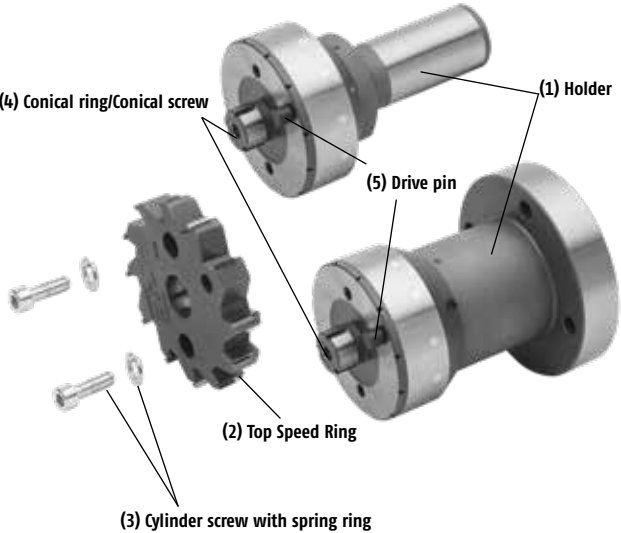
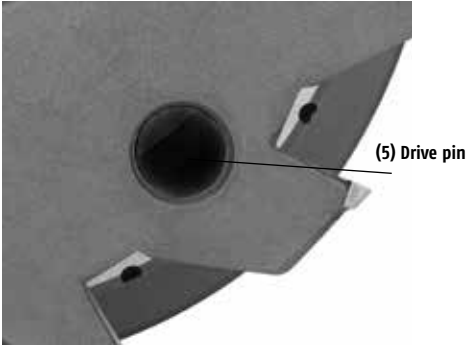
Type 51313, 51325

<p>1. Clean all parts carefully and grease holder (1) with withe assembly paste on the plan surface and pilot</p>	
<p>2. Only apply conical ring/conical screw (4) do not tighten</p>	
<p>3. Slip the Top Speed Ring (2) onto the holder (1) (Bevel lead of the cutting edge to the front). The dotting mark of the holder (1) and the dotting mark on the Top Speed Ring (2) must have the same position. See picture page 45.</p>	
<p>4. Before tightening press the drive pin (5) to the Top Speed Ring (2) against the direction of rotation</p>	
<p>5. Tighten the conical ring/conical screw (4) in the direction of the arrow, with a torque wrench (Torque M (Nm) check marking on ring)</p>	
<p>6. Tighten the cylinder screw with spring ring (3)</p>	



DIATOOOL Assembly video  
[https://youtu.be/jP0h3\\_f-3dc](https://youtu.be/jP0h3_f-3dc)





## Special Reamers

### Product Features:

- Solid and expandable  $\varnothing$  5,600 – 100,599 mm
- With and without internal coolant supply
- Different cutting materials and coatings

### Product Advantages:

- Short delivery times
- Tool design as per application requirements
- Very stable thanks to the monoblock design = excellent bore quality
- All reamers are ground to the nominal size, e.g. first bore = good bore!
- No diameter setting
- Short machining times thanks to high feeds and multi-blade design
- Wear compensation through the simple expansion feature
- High economic efficiency thanks to repeated retippings
- Repaired / retipped reamers have the same tool life as new reamers



# Special Reamers

The reamer specialist

### Coolant

- to the cutting edge
- central
- without

Type Solid	Type Expandable
<input type="checkbox"/> HM (Carbide)	<input type="checkbox"/> HM (Carbide)
<input type="checkbox"/> HM + Coating	<input type="checkbox"/> HM + Coating
<input type="checkbox"/> CT (CERMET)	<input type="checkbox"/> CT (CERMET)
<input type="checkbox"/> CT + Coating	<input type="checkbox"/> CT + Coating
<input type="checkbox"/> PKD (PKD / PCD)	<input type="checkbox"/> PKD (PKD / PCD)

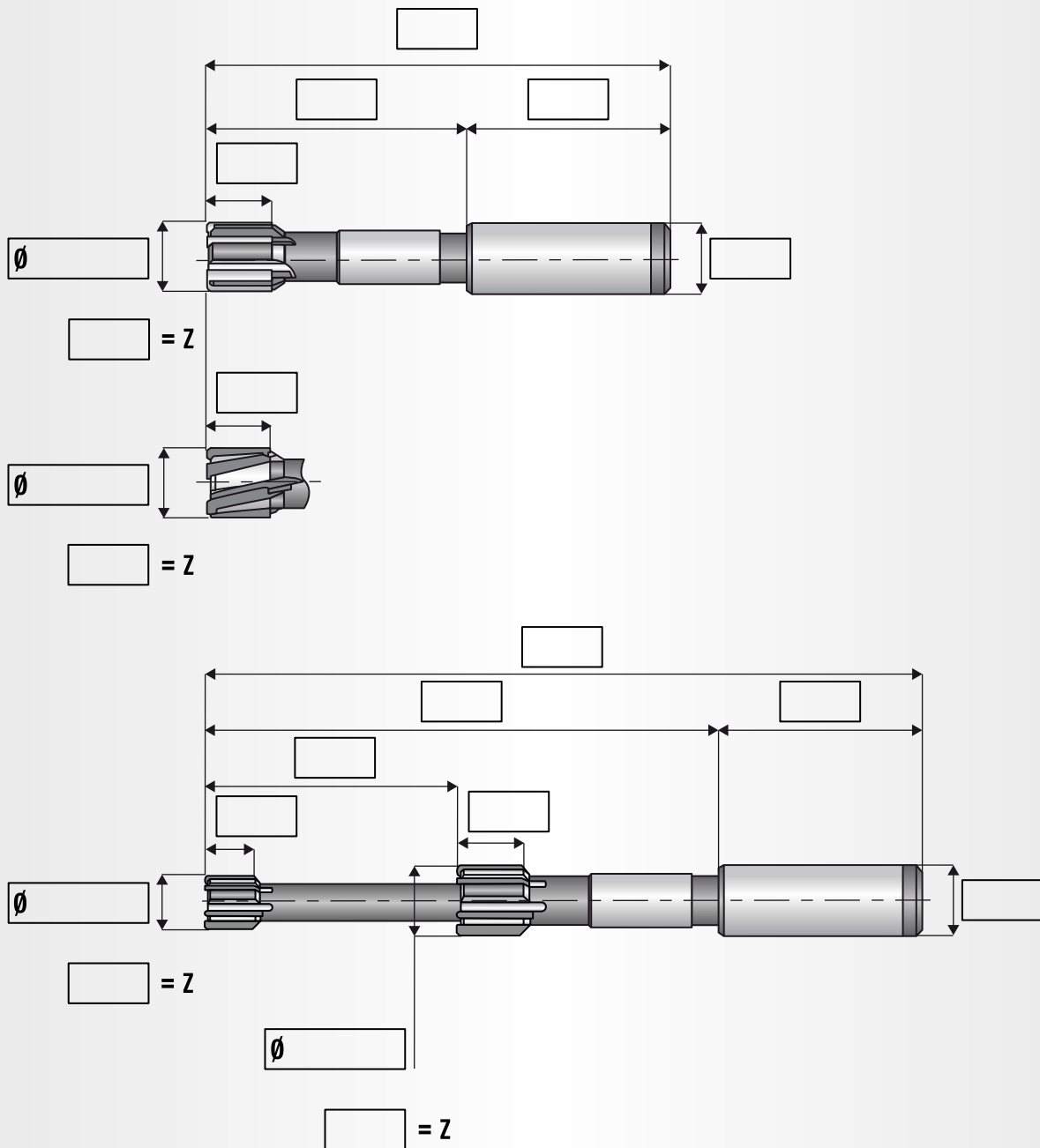

To propose the best tooling design please fill out the questionnaire page 75 and add a part drawing.

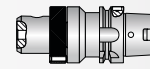

## Compensation Holder

### Product Features:

- Compensation holder for HSK, SK, CAT, MAS / BT
- With internal coolant supply
- For tools with Weldon flat, Cyl. shank and flange Module

### Product Advantages:

- Correction of runout errors and misalignment
- Easy to set
- Maximum process safety due to correction of runout
- Extended tool life due to correction of runout
- Highest quality of bores due to correction of runout

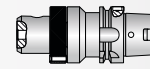

# Compensation Holder

**The reamer specialist**

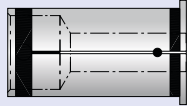
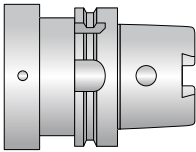
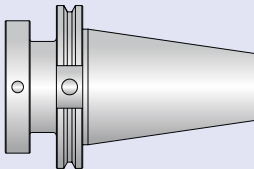
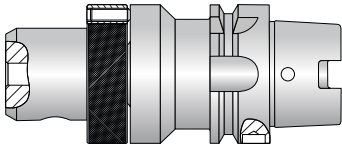
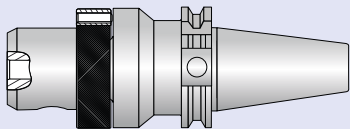
Type			Page
58030	Flange Module		52
58030	Intermediate sleeve		53
58201	HSK		54
58021	SK		55
58122	MAS / BT		56
58121	CAT		57
58010 / 58011	HSK		58
58020 / 58021	SK / ISO		59
58120 / 58121	CAT		60
<b>Handling instructions</b>			<b>61 - 65</b>

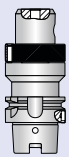
**Compensation Holder**

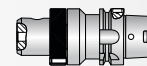

**Hydraulic Chuck**

With radial and angular adjustment

With module / flange (for compensation holder)

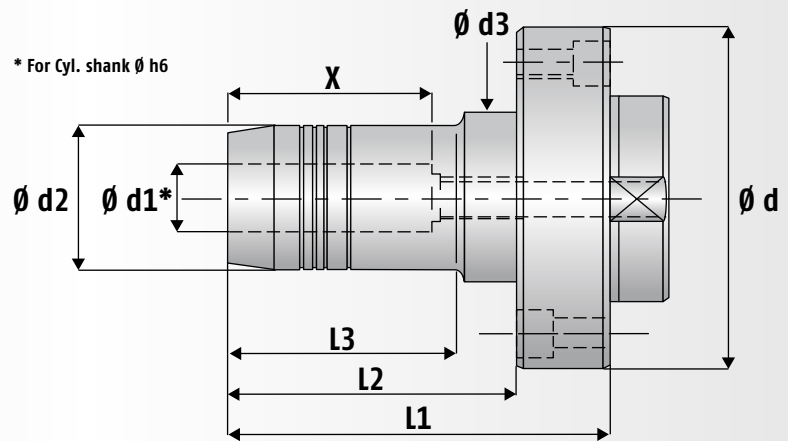

Article No.	Module Ø d mm	Ø d1 mm	Ø d2 mm	Ø d3 mm	L1 mm	L2 mm	L3 mm	X
58030.041	60	12	32	-	70	57	-	47
58030.042	60	16	32	-	70	57	-	52
58030.043	60	20	32	-	70	57	-	52
58030.045	70	16	38	-	50	36	-	48
58030.046	70	16	38	-	82,5	68,5	-	52
58030.047	70	20	41,5	-	50	35	-	52
58030.048	70	20	40	-	82,5	67,5	-	52
58030.054	80	12	32	50	77,5	62,5	44,5	49
58030.055	80	16	38	50	82,5	67,5	51,5	52
58030.056	80	20	42	50	82,5	67,5	53	52
58030.057	80	25	50	-	90	75	-	58
58030.104	100	12	32	50	90	66	47	47
58030.105	100	16	38	-	100	76	-	52
58030.106	100	20	42	50	90	66	53	52
58030.107	100	25	50	-	100	76	-	58
58030.108	100	32	60	-	103	79	-	62

- With internal coolant supply
- Handling instructions page 61 - 63
- Other versions on request

To be used with type:

58201 HSK

58021 SK

58122 MAS/BT

58121 CAT



Order: Complete holder

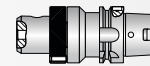

**Intermediate sleeve  
Sealing**

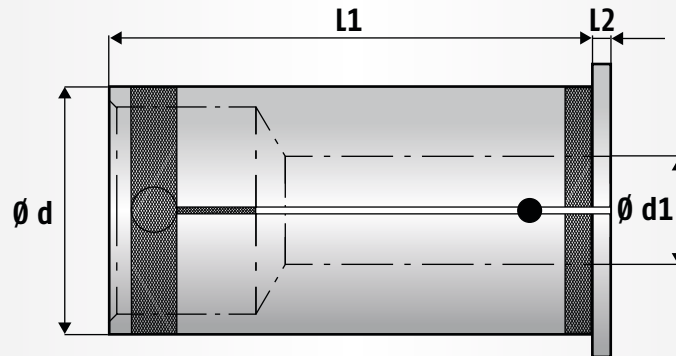

Article No.	$\varnothing d$ mm	$\varnothing d1$ mm / Inch	L1 mm	L2 mm
58030.220	32	25	63	2.5
58030.221	32	20		
58030.222	32	16		
58030.223	32	12		
58030.240	32	1"	63	2.5
58030.241	32	3/4"		
58030.242	32	5/8"		
58030.243	32	1/2"		
58030.230	25	20	57	2.5
58030.231	25	16		
58030.232	25	12		
58030.250	25	3/4"	57	2.5
58030.251	25	5/8"		
58030.252	25	1/2"		

To be used with type:

58030





# Type 58201

The reamer specialist

## Compensation Holder

HSK-A DIN 69893 A

With module / flange (radially adjustable)

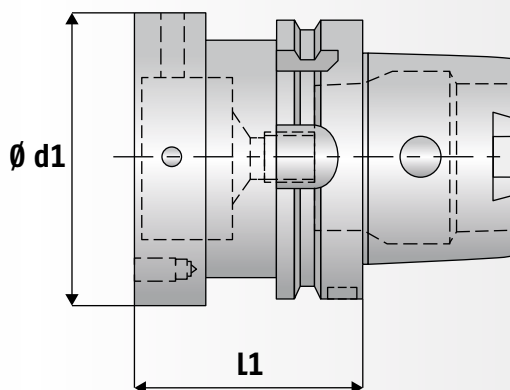

Article No.	HSK-A	Module $\varnothing d$ mm	L1 mm
58201.001	40	60	55
58201.101	50	60	60
58201.102	50	70	60
58201.103	50	80	60
58201.201	63	60	60
58201.205	63	60	110
58201.204	63	70	55
58201.206	63	70	60
58201.202	63	80	60
58201.203	63	100	65
58201.301	80	60	50
58201.304	80	70	60
58201.302	80	80	60
58201.303	80	100	65
58201.401	100	60	55
58201.407	100	70	55
58201.408	100	70	80
58201.402	100	80	45
58201.403	100	80	85
58201.404	100	80	130
58201.405	100	100	65
58201.406	100	100	170

- With internal coolant supply
- Handling instructions page 61 - 63
- Other versions on request

To be used with type:



Order: Complete holder

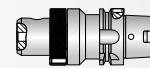

# Type 58021

The reamer specialist

## Compensation Holder

SK / ISO DIN 69871 Form AD+B

With module / flange (radially adjustable)

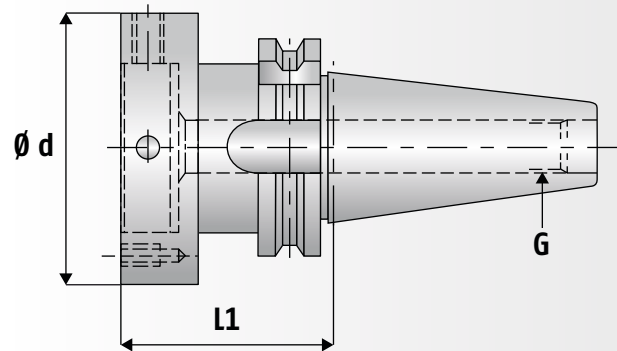

Article No.	Taper	Module $\varnothing d$ mm	G	L1 mm
58021.151	SK 40	60	M16	50
58021.152	SK 40	70	M16	50
58021.150	SK 40	80	M16	55
58021.100	SK 40	100	M16	60
58021.251	SK 50	60	M24	50
58021.252	SK 50	70	M24	50
58021.250	SK 50	80	M24	50
58021.200	SK 50	100	M24	60

- With internal coolant supply
- Handling instructions page 61 - 63
- Other versions on request

To be used with type:

50776

50325

58030



Order: Complete holder

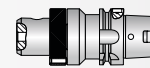

## Compensation Holder

MAS / BT Form AD+B

With module / flange (radially adjustable)

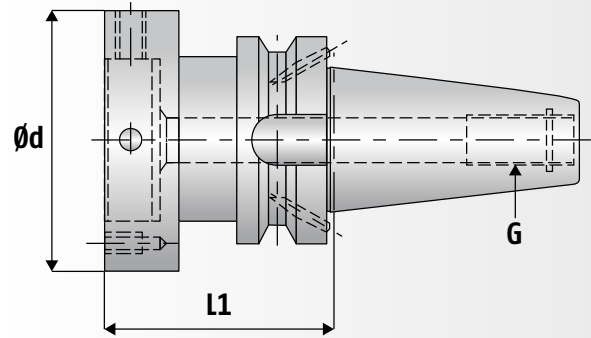

Article No.	Taper	Module $\varnothing d$ mm	G	L1 mm
58122.010	BT 30	60	M12	45
58122.011	BT 30	80	M12	50
58122.007	BT 40	60	M16	55
58122.008	BT 40	60	M16	110
58122.006	BT 40	70	M16	50
58122.001	BT 40	80	M16	65
58122.002	BT 40	80	M16	100
58122.003	BT 40	100	M16	60
58122.009	BT 50	60	M24	70
58122.012	BT 50	70	M24	70
58122.004	BT 50	80	M24	70
58122.005	BT 50	100	M24	70

- With internal coolant supply
- Handling instructions page 61 - 63
- Other versions on request

To be used with type:



Order: Complete holder



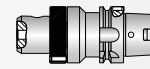

**Compensation Holder**

CAT after ASME B5.50

With module / flange (radially adjustable)

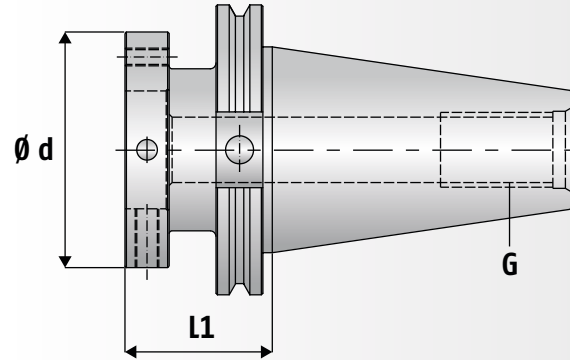

Article No.	Taper	Module $\varnothing d$ mm	G	L1 mm
58121.102	CAT 40 (AD+B)	60	M16	50
58121.103	CAT 40 (AD+B)	60	5/8"	50
58121.105	CAT 40 (AD+B)	70	5/8"	50
58121.150	CAT 40 (AD+B)	80	M 16	60
58121.151	CAT 40 (AD+B)	80	5/8 "	60
58121.100	CAT 40 (AD+B)	100	M 16	60
58121.101	CAT 40 (AD+B)	100	5/8 "	60
58121.201	CAT 50 (AD)	60	1"	50
58121.202	CAT 50 (AD)	70	1"	50
58121.250	CAT 50 (AD)	80	1"	50
58121.200	CAT 50 (AD)	100	1"	80

- With internal coolant supply
- Handling instructions page 61 - 63
- Other versions on request

To be used with type:



Order: Complete holder

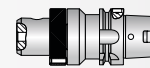

# Type 58010, 58011

The reamer specialist

## Compensation Holder

HSK DIN 69893 A

Weldon DIN 1835/1 Form B

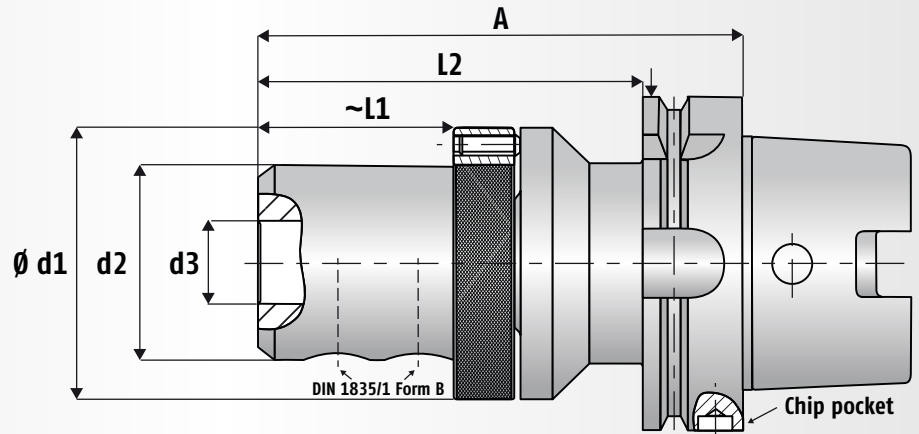

Article No.	Ø d3 mm (H5)	HSK	Ø d2 mm	Ø d1 mm	A mm	L1 mm	L2 mm
58010004	Ø 12 x 45	63	42	63	118	36	
58010005	Ø 16 x 48	63	42	63	118	36	
58010006	Ø 20 x 50	63	58	81	121,5	35	
58010007	Ø 25 x 56	63	58	81	145,5	58	
58010008	Ø 32 x 60	63	58	81	149,5	62	
58011007	Ø 25 x 56	100	58	81	143,50	58	114,50
58011008	Ø 32 x 60	100	58	81	147,50	62	118,50

- With internal coolant supply
- Handling instructions page 64 - 65
- With Balluff Chip pocket Ø 10 mm x 5 mm deep
- Special lengths or other connections on requests

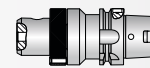

# Type 58020, 58021

The reamer specialist

## Compensation Holder

SK / ISO DIN 69871 AD/B

Weldon DIN 1835/1 Form B

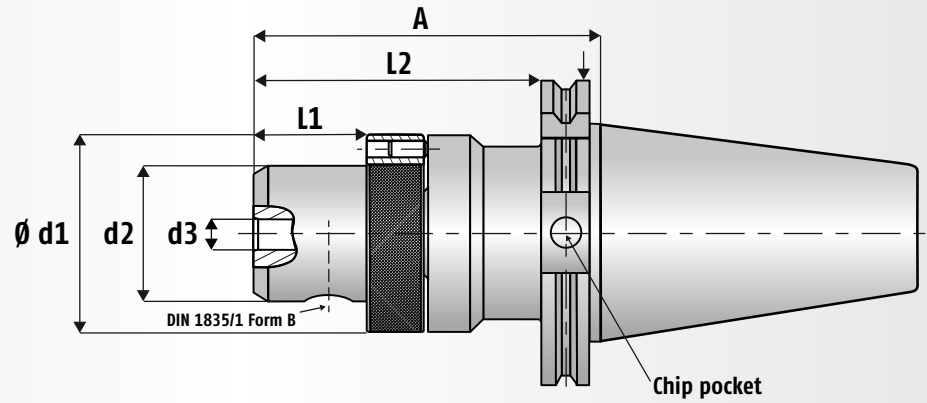

Article No.	∅ d3 mm (H5)	SK	∅ d2 mm	∅ d1 mm	A mm	L1 mm	L2 mm
58020004	∅ 12 x 45	40	42	63	111	36	
58020005	∅ 16 x 48	40	42	63	111	36	
58020006	∅ 20 x 50	40	58	81	114	39	
58020007	∅ 25 x 56	40	58	81	138	58	
58020008	∅ 32 x 60	40	58	81	142	62	
58021004	∅ 12 x 45	50	42	63	111	36	92
58021005	∅ 16 x 48	50	42	63	111	36	92
58021006	∅ 20 x 50	50	58	81	114	39	95
58021007	∅ 25 x 56	50	58	81	133	58	114
58021008	∅ 32 x 60	50	58	81	140	62	121

- With internal coolant supply
- Handling instructions page 64 - 65
- With Balluff Chip pocket ∅ 10 mm x 5 mm deep
- Special lengths or other connections on requests

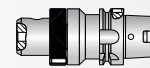

# Type 58120, 58121

The reamer specialist

## Compensation Holder

CAT to ASME B5.50

Weldon DIN 1835/1 Form B

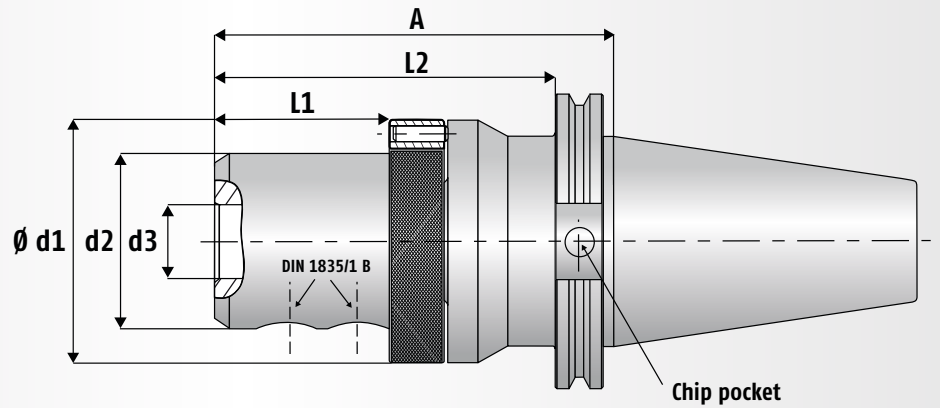

Article No.	$\varnothing d3$ mm (H5)	CAT (AD + B)	$\varnothing d2$ mm	$\varnothing d1$ mm	A mm	L1 mm	L2 mm
58120004	$\varnothing 12 \times 45$	40	42	63	111	36	
58120005	$\varnothing 16 \times 48$	40	42	63	111	36	
58120006	$\varnothing 20 \times 50$	40	58	81	114	39	
58120007	$\varnothing 25 \times 56$	40	58	81	138	58	
58120008	$\varnothing 32 \times 60$	40	58	81	142	62	
58121004	$\varnothing 12 \times 45$	50	42	63	111	36	92
58121005	$\varnothing 16 \times 48$	50	42	63	111	36	92
58121006	$\varnothing 20 \times 50$	50	58	81	114	39	95
58121007	$\varnothing 25 \times 56$	50	58	81	133	58	114
58121008	$\varnothing 32 \times 60$	50	58	81	140	62	121

- With internal coolant supply
- Handling instructions page 64 - 65
- With Balluff Chip pocket  $\varnothing 10$  mm x 5 mm deep
- Special lengths or other connections on requests

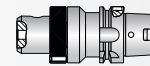

# Handling Instructions

The reamer specialist

Type  
58030

<p><b>1.</b> <b>Cleaning:</b> Attention should be paid to the cleanliness of the holder bore and reamer shank.</p>	<p>Cleaning</p>																		
<p><b>2.</b> <b>Clamping:</b> Insert reamer up to the end stop. Clamp the shaft by turning the clamping screw up to the end stop.</p>	<p>Turning the clamping screw up to the end stop (max. 10 Nm)</p> <p>0,00 mm</p>																		
<p><b>3.</b> <b>Clamping shaft:</b> Clamp only tool shanks as per of DIN 1835 Form A and Form B.</p>	<p>DIN 1835 Form A DIN 1835 Form B to 20 mm</p>																		
<p><b>4.</b> <b>Temperature:</b> Optimal temperature range between 10 - 50 °C. Do not use with temperatures above 80 °C</p>	<p>Optimal operation temperature</p> <p>do not use with temperatures above 80 °C</p> <p>10 50 80 °C</p>																		
<p><b>5.</b> <b>Storage:</b> Store the hydraulic chuck untensioned, cleaned and lightly oiled.</p>																			
<p><b>6.</b> <b>Torque:</b> Torque depending on the clamping diameter. These values are valid for shanks clamping as per DIN.</p> <p>1) DIN 1835 A DIN 6535 HA 2) DIN 1835 B DIN 6535 HB</p>	<table border="1"> <thead> <tr> <th>Clamping-Ø mm</th> <th>Moment (Nm)</th> <th>Tool shaft tolerance</th> </tr> </thead> <tbody> <tr> <td>12</td> <td>min. 110</td> <td>h6</td> </tr> <tr> <td>16</td> <td>min. 140</td> <td>h6</td> </tr> <tr> <td>20</td> <td>min. 200</td> <td>h6</td> </tr> <tr> <td>25</td> <td>min. 250</td> <td>h6</td> </tr> <tr> <td>32</td> <td>min. 250</td> <td>h6</td> </tr> </tbody> </table>	Clamping-Ø mm	Moment (Nm)	Tool shaft tolerance	12	min. 110	h6	16	min. 140	h6	20	min. 200	h6	25	min. 250	h6	32	min. 250	h6
Clamping-Ø mm	Moment (Nm)	Tool shaft tolerance																	
12	min. 110	h6																	
16	min. 140	h6																	
20	min. 200	h6																	
25	min. 250	h6																	
32	min. 250	h6																	
<p><b>7.</b> <b>Precision:</b> Maximum concentricity and repeating accuracy because of cylinder shafts being centrally clamped.</p> <p>I5 = from Ø 6 mm to Ø 20 mm = 2 x d1, over Ø 20 mm = 1,5 x d1</p>	<p>Run out</p> <p>0.003 A</p> <p>d1</p> <p>I5</p>																		

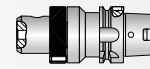

# Handling Instructions

Type

50776, 58201, 58021, 58122, 58121

<p><b>1.</b> Loosen all fixing screws and tighten them slightly.</p>	
<p><b>2.</b> Loosen the setting screws.</p>	
<p><b>3.</b> Set dial gauge onto the concentricity control zone of the tool. Use a 0,001 mm (1<math>\mu</math>m) dial gauge.</p>	
<p><b>4.</b> Turn the tool 360° and go onto the highest run-out indication.</p>	

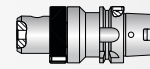

# Handling Instructions

Type

50776, 58201, 58021, 58122, 58121

<p><b>5.</b> Set the Allan-key at the closest screw vertically below the dial gauge and tighten it carefully until about half of the run-out is eliminated.</p>	
<p><b>6.</b> If there is not a setting screw directly below the gauge, tighten the closest screw below the gauge until the runout is further reduced. Turn the reamer 360° and check run-out.</p>	
<p><b>7.</b> If necessary repeat point 5 &amp; 6 until the run-out is completely eliminated.</p>	
<p><b>8.</b> Tighten all fixing screws evenly. Turn the reamer again 360° and check the concentricity. Important: Take-off the Allan key!</p>	

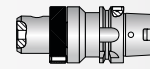

# Handling Instructions

The reamer specialist

Type

58010, 58011, 58020, 58021, 58120, 58121

<p><b>1.</b> Insert tool into holder and tighten the Weldon screw.</p>	
<p><b>2.</b> Locking screw is set by the manufacturer. Do not touch it!</p>	
<p><b>3.</b> Loosen all setting screws to allow the setting ring to be turned freely within the set 60°.</p>	
<p><b>4.</b> Set dial gauge onto the concentricity control zone of the tool. Use a 0,001 mm (1 ym) dial gauge. Turn the tool 360° and go onto the highest run-out indication.</p>	



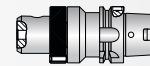

# Handling Instructions

## Type

58010, 58011, 58020, 58021, 58120, 58121

<p>5.</p>	<p>Turn the setting ring until the setting screw closest to the highest run-out is positioned as close as vertically below the dial gauge.</p>	
<p>6.</p>	<p>Set the Allan-key at the closest screw vertically below the dial gauge and tighten it carefully until about half of the run-out is eliminated.</p>	
<p>7.</p>	<p>If there is not a setting screw directly below the gauge, tighten the closest screw below the gauge until the runout is further reduced. Turn the reamer 360° and check run-out.</p>	
<p>8.</p>	<p>If necessary repeat point 6 &amp; 7 until the run-out is completely eliminated.</p>	
<p>9.</p>	<p>Turn the reamer again 360° and check the concentricity. Important: Take-off the Allan key!</p>	

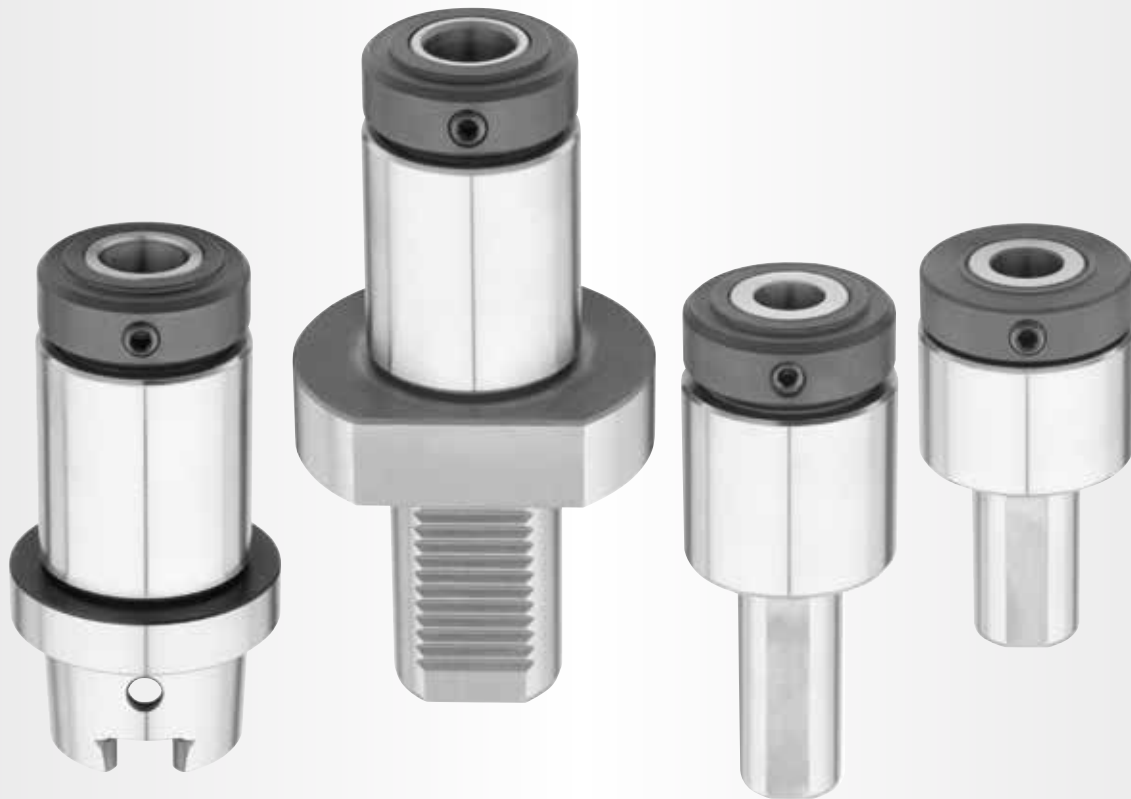
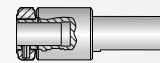

## Floating Holder with Roll-Technology

### Product Features:

- For multi-bladed high performance reamers
- Radial play 0,01 mm to 2 mm (depending on size)
- Internal coolant supply (water, oil, air, MQL)
- Up to max. 80 bar coolant pressure
- With roll-technology for highest performance

### Product Advantages:

- For high revolutions and feed rates
- No chatter when starting the cut
- Permanently high precision and tool life
- Less scrap
- No wear parts, therefore no cost-intensive inventory
- With roll technology less power is needed to deflect (no stick-slip-effect)

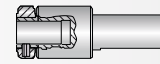

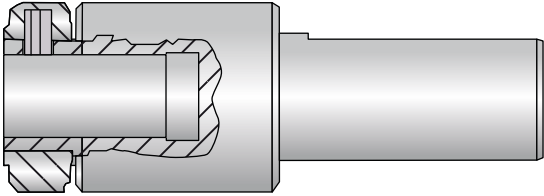
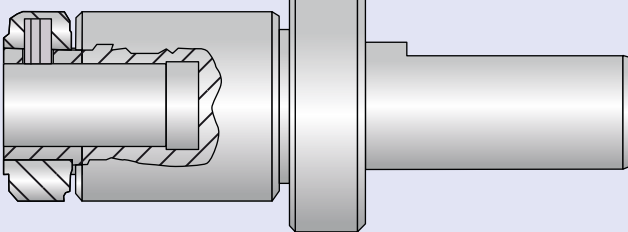
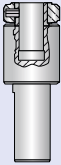
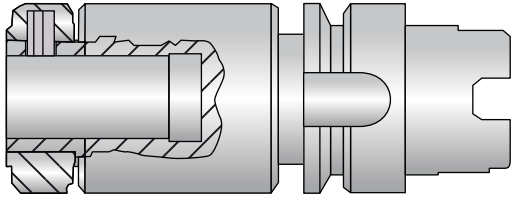
	Type			Page
	58302	ZYL / CYL		68
	58303	VDI		69
 <p>Floating Holder</p>	58301	HSK		70
	Tech. information			71

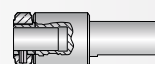

# Type 58302

The reamer specialist

## Floating Holder with Roll-Technology

For multi-bladed high performance reamers

With internal coolant supply

With straight shank and flat

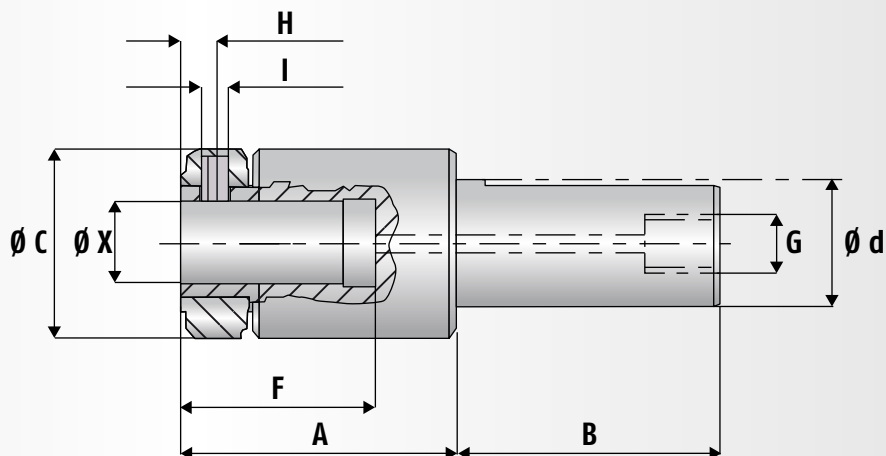

Article No.	Floating holder		Ø X mm	Overall dimensions						Radial play mm	Pretension Nm
	Ø d mm	B mm		Ø C mm	A mm	F mm	H mm	I mm	G mm		
58302.001	20	40	10	38,5	47	25	6	M 6	1/8"	0,08	1,2
58302.002	25	40	10	38,5	47	25	6	M 6	1/4"	0,08	1,2
58302.003	32	40	10	38,5	47	25	6	M 6	3/8"	0,08	1,2
58302.004	20	40	12	38,5	47	25	6	M 6	1/8"	0,08	1,0
58302.005	25	40	12	38,5	47	25	6	M 6	1/4"	0,08	1,0
58302.006	32	40	12	38,5	47	25	6	M 6	3/8"	0,08	1,0
58302.007	20	50	16	49	65	40	9,5	M 8	1/8"	0,10	1,5
58302.008	25	60	16	49	65	40	9,5	M 8	1/4"	0,10	1,5
58302.009	32	80	16	49	65	40	9,5	M 8	3/8"	0,10	1,5
58302.010	40	80	16	49	65	40	9,5	M 8	1/2"	0,10	1,5
58302.011	20	50	20	49	75	50	9,5	M 8	1/8"	0,12	1,9
58302.012	25	60	20	49	75	50	9,5	M 8	1/4"	0,12	1,9
58302.013	32	80	20	49	75	50	9,5	M 8	3/8"	0,12	1,9
58302.014	40	80	20	49	75	50	9,5	M 8	1/2"	0,12	1,9
58302.015	25	60	25	59	85	60	9,5	M 10	1/4"	0,12	2,5
58302.016	32	80	25	59	85	60	9,5	M 10	3/8"	0,12	2,5
58302.017	40	80	25	59	85	60	9,5	M 10	1/2"	0,12	2,5
58302.018	32	80	32	80	94	63	12,5	M 12	3/8"	0,12	3,5
58302.019	40	80	32	80	94	63	12,5	M 12	1/2"	0,12	3,5

- Additional sizes and special designs available on request
- Radial play also as per customer specification
- Tech. information page 71

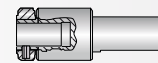

# Type 58303

The reamer specialist

**Floating Holder with Roll-Technology**  
 For multi-bladed high performance reamers  
 With internal coolant supply  
 With VDI DIN straight shank and flat

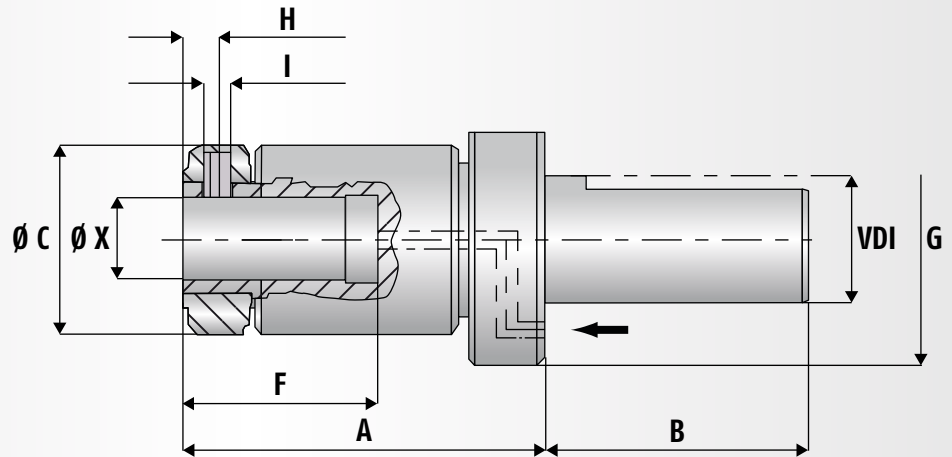

Article No.	Floating holder		Ø X mm	Overall dimensions						Radial play mm	Pretension Nm
	VDI mm	B mm		Ø C mm	A mm	F mm	H mm	I mm	G mm		
58303.001	30	55	10	38,5	76	25	6	M 6	68	0,08	1,2
58303.002	40	63	10	38,5	76	25	6	M 6	83	0,08	1,2
58303.003	30	55	12	38,5	76	25	6	M 6	68	0,08	1,0
58303.004	40	63	12	38,5	76	25	6	M 6	83	0,08	1,0
58303.005	30	55	16	49	95	40	9,5	M 8	68	0,08	1,5
58303.006	40	63	16	49	95	40	9,5	M 8	83	0,08	1,5
58303.007	50	78	16	49	95	40	9,5	M 8	98	0,08	1,5
58303.008	30	55	20	49	105	50	9,5	M 8	68	0,10	1,9
58303.009	40	63	20	49	105	50	9,5	M 8	83	0,10	1,9
58303.010	50	78	20	49	105	50	9,5	M 8	98	0,10	1,9
58303.011	30	55	25	59	114	60	9,5	M 10	68	0,12	2,5
58303.012	40	63	25	59	114	60	9,5	M 10	83	0,12	2,5
58303.013	50	78	25	59	114	60	9,5	M 10	98	0,12	2,5
58303.014	30	55	32	80	119	63	12,5	M 12	68	0,12	3,5
58303.015	40	63	32	80	119	63	12,5	M 12	83	0,12	3,5
58303.016	50	78	32	80	119	63	12,5	M 12	98	0,12	3,5

- Additional sizes and special designs available on request
- Radial play also as per customer specification
- Option with gearing available. Abbreviation: VZ
- Tech. information page 71

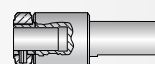

# Type 58301

The reamer specialist

**Floating Holder with Roll-Technology**  
 For multi-bladed high performance reamers  
 With internal coolant supply  
 With HSK-A

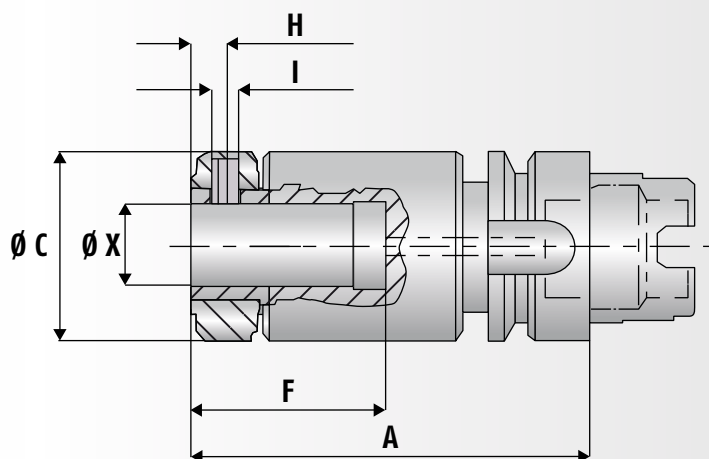

Article No.	Floating holder		Overall dimensions					Radial play mm	Pretension Nm
	HSK-A mm	Ø X mm	Ø C mm	A mm	F mm	H mm	I mm		
58301.001	32	10	38,5	83	25	6	M 6	0,08	1,2
58301.002	32	12	38,5	83	25	6	M 6	0,08	1
58301.003	32	16	49	104	40	9,5	M 8	0,08	1,5
58301.004	63	16	49	97	40	9,5	M 8	0,08	1,5
58301.005	32	20	49	114	50	9,5	M 8	0,08	1,9
58301.006	63	20	49	107	50	9,5	M 8	0,08	1,9
58301.007	32	25	59	125	60	9,5	M 10	0,08	2,5
58301.008	63	25	59	132	60	9,5	M 10	0,08	2,5
58301.009	63	32	80	137	63	12,5	M 12	0,08	3,5

- Additional sizes and special designs available on request
- Radial play also as per customer specification
- Tech. information page 71

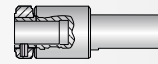

# Tech. Information

The reamer specialist

## Application of the Floating Holder

Floating holders are used for fine finishing of bores (reaming) to compensate for lateral misalignment between tool and work piece.

Such an error can be produced by:

- Machining in different clampings
- Cycle errors and positional errors of the spindle
- Wear of the machine
- As a result of a crash
- Heat development

## Roll-technology

With the roll-technology a linear-support is given through the cylinder rolls. In comparison to the ball-technology there are no punctual wear marks and the floating holder is not hindered in his movement. In consequence of the roll-technology less power is needed to deflect the tool (no stick-slip-effect).

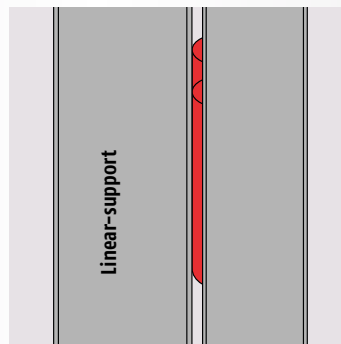

Cylinderroll-technology

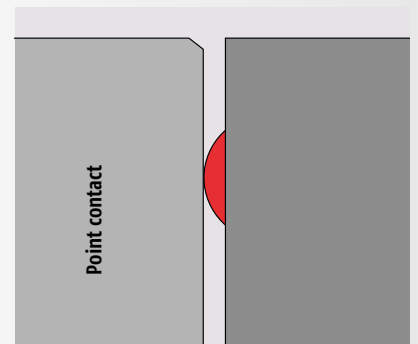

Ball-technology

## Definition of the Floating Holder

Measure the misalignment and define the radial play (picture 1).  
 Should the radial play deviate from the standard catalogue value, the measured value should be mentioned when ordering.  
 The diameter of the reamer should not be bigger as the outside diameter of the floating holder (C).  
 The ideal proportion is 0,5 : 1 (picture 2)

Picture 1

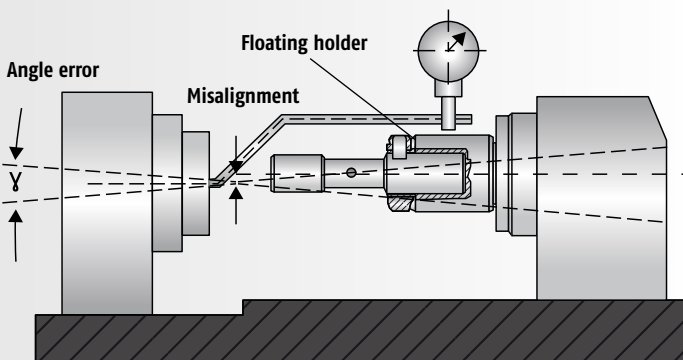



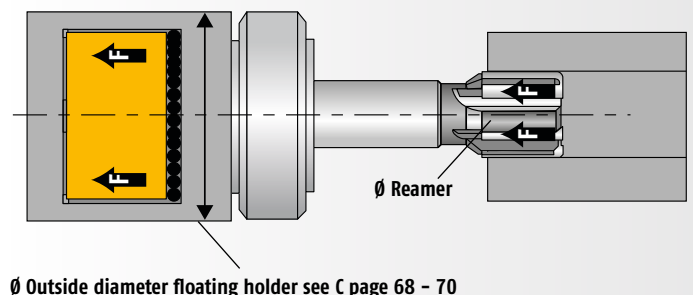

Picture 2



Ø Outside diameter floating holder see C page 68 - 70



Overview reaming program

Reamer Ø	Monoblock	Reaming head	Cutting ring	Top Speed Ring
				
5,6 - 9,6				
9,6 - 20				
20 - 30				
30 - 50				
50 - 60				
60 - 70				
70 - 90				
90 - 205				
200 - 225				



<p style="text-align: center;"><b>i</b> Information</p>	Theme	Page
	Geometries	74
	Recommendations	75
	Recommended cutting datas	76 - 79
	Correction of reaming problems	80
	Questionnaire	81
	Repair Service	82
	Media	83

# Geometries

	Geometry	Bevel lead angles	Flute form + chip flow	Cutting materials + coatings	Material to be machined
Standard geometries	G01			Carbide, CERMET, coatings	Steel, GG, GGG, copper alloys
	G01A			Carbide, coatings	High alloy steels, stainless steels, aluminium
	G02			Carbide, CERMET, coatings	Steel, GG, GGG, copper alloys
	G02A			Carbide, coatings	High alloy steels, stainless steels, aluminium
	G03			Carbide	Titanium
	G05			Carbide, CERMET, coatings	Steel, GG, GGG, copper alloys
	G05A			Carbide, coatings	High alloy steels, stainless steels, aluminium
	G08			Carbide, CERMET, coatings	Steel, GG, GGG, copper alloys
	G08A			Carbide, coatings	High alloy steels, stainless steels, aluminium
	G09			Carbide, CERMET, coatings	Steel, GG, GGG, copper alloys
	G11			PCD	Aluminium
	G99	Special bevel lead for lathes		Carbide, CERMET, coatings	All materials
Special geometries	<b>Face cutting geometries</b>				
	G06			Carbide, CERMET, coatings	Steel, GG, GGG, copper alloys
	G06A			Carbide, coatings	High alloy steels, stainless steels, aluminium
	G0611			PCD	Aluminium
	<b>Face cutting geometries for increased positional accuracy</b>				
	G065			Carbide, CERMET, coatings	Steel, GG, GGG, copper alloys
	G065A			Carbide, coatings	High alloy steels, stainless steels, aluminium
	<b>Chip breaking geometries</b>				
	G09B			Carbide, CERMET, coatings	Steel, GGG
	G1405			Carbide, CERMET coatings	Steel, GGG

# Geometry Recommendations

Material to be machined		Cutting material	Through holes							Blind holes					
			Standard		Increased requirements for					Standard	Increased requirements for				
					Position	Surface / Feed		Chip control			Chip break	Position	Surface	Chip break	
			Straight fluted	Left hand fluted	Straight fluted	Straight fluted	Left hand fluted	Straight fluted	Left hand fluted	Straight fluted	Straight fluted	Straight fluted	Straight fluted		
P	Non alloy and low alloy steels, lead alloys	Carbide	G01	G05	G08	G02	G05	G09	G05	G1405	G01	G08	G02	G1405	
		Carbide coated													
		CERMET													
		CERMET coated													
H	Hardened steels <45HRC	Carbide coated	G01A		G08A						G01A	G08A			
	Hardened steels >45 ≤65 HRC	Carbide coated													
M	High alloy steels	Carbide	G01A	G05A	G08A	G02A	G05A	G09	G05A	G1405	G01A	G08A	G02A	G1405	
		Carbide coated													
	Stainless steel	Carbide													
		Carbide coated													
S	Special alloys, Inconel, Nimonic, Hastelloy	Carbide	G01A								G01A				
		Carbide coated													
	Titanium, titanium alloys	Carbide	G03									G03			
		Carbide coated													
K	Gray cast iron, alloy gray cast iron	Carbide	G01		G08	G02					G01	G08	G02		
		Carbide coated													
	Spheroidal graphite cast iron, ferritic / perlitic <600N/mm²	Carbide	G01		G08	G02						G01	G08	G02	
		Carbide coated													
		CERMET													
		CERMET coated													
	Spheroidal graphite cast iron, perlitic malleble iron	Carbide	G01	G05	G08	G02	G05	G09	G05	G05	G1405	G01	G08	G02	G1405
		Carbide coated													
		CERMET													
		CERMET coated													
	Alloyed spheroidal graphite cast iron, vermicular cast iron	Carbide	G01	G05	G08	G02	G05	G09	G05			G01	G08	G02	
		Carbide coated													
Copper alloys: brass, bronze	Carbide	G01	G05	G08	G02	G05	G09	G05			G01	G08	G02		
	CERMET														
Wrought aluminium alloys	Carbide	G01A	G05A	G08A	G02A	G05A	G09	G05A			G01A	G08A	G02A		
	Carbide coated	G01	G05	G08	G02	G05	G09	G05			G01	G08	G02		
	PCD	G11									G11				
Cast aluminium alloy: <8% Si, magnesium alloy	Carbide	G01A	G05A	G08A	G02A	G05A	G09	G05A			G01A	G08A	G02A		
	Carbide coated														
	PCD	G11									G11				
Cast aluminium alloy >8% Si	Carbide	G01A		G08A	G02A						G01A	G08A	G02A		
	Carbide coated														
	PCD	G11									G11				

# Recommended Cutting Data

The reamer specialist

For straight fluted reamers

Geometries G01, G01A, G02, G02A, G03, G06, G06A, G0611, G065, G065A, G08, G08A, G11, G99

Material group	Material	Strength N/mm <sup>2</sup>	hardness HB	Reamer ø [mm]	Reaming allowance			Feed per tooth			Cutting speed Vc = [m/min]														
					ø [mm]			Fz=mm / rev. per tooth			Carbide	Carbide coated					CERMET coated								
					min.	norm	max.	min.	norm	max.		TiN	TiAlN	AlTiN	AlCrN	CERMET	TiAlN	AlTiN							
					5,600 - 11,899	11,900 - 18,899	18,900 - 32,599	32,600 - 60,599	60,600 - 205,599	0,10		0,15	0,20	0,05	0,10	0,13	min.	norm	max.	min.	norm	max.			
P	Non-alloy and low alloy steels St37-2/1.0037 95Mn28/1.0715 St52-2/1.0050	<900		5,600 - 11,899	0,10	0,15	0,20	0,05	0,10	0,13	min.	6	60	60			100	100							
				11,900 - 18,899	0,10	0,20	0,25	0,06	0,12	0,16									norm	8	90	110	150	150	
				18,900 - 32,599	0,10	0,20	0,30	0,09	0,14	0,20									max.	10	120	140	200	200	
				32,600 - 60,599	0,20	0,30	0,40	0,11	0,16	0,22															
	Lead alloyed steels, lead alloys 95MnPb28/1.0718				5,600 - 11,899	0,10	0,15	0,20	0,05	0,10	0,13	min.	20	60	60			100	100						
					11,900 - 18,899	0,10	0,20	0,25	0,06	0,12	0,16									norm	40	90	110	150	150
					18,900 - 32,599	0,10	0,20	0,30	0,09	0,14	0,20									max.	50	120	140	200	200
					32,600 - 60,599	0,20	0,30	0,40	0,11	0,16	0,22														
	Non alloy and low alloy steels 42CrMo4/1.7225 CK60/1.1221	900 - 1300			5,600 - 11,899	0,10	0,15	0,20	0,05	0,10	0,13	min.	6	60	80			80	80						
					11,900 - 18,899	0,10	0,20	0,25	0,06	0,11	0,14									norm	8	80	100	110	110
					18,900 - 32,599	0,10	0,20	0,30	0,07	0,12	0,16									max.	10	100	120	150	150
					32,600 - 60,599	0,20	0,30	0,40	0,08	0,14	0,20														
H	Hardened steels <45HRC	1400		5,600 - 11,899	0,10	0,15	0,20	0,04	0,08	0,10	min.							60							
				11,900 - 18,899	0,10	0,20	0,25	0,05	0,10	0,13									norm						80
				18,900 - 32,599	0,10	0,20	0,30	0,07	0,11	0,16									max.						100
				32,600 - 60,599	0,20	0,30	0,40	0,09	0,13	0,18															
	Hardened steels 45 - 65HRC	1800			5,600 - 11,899	0,10	0,15	0,20	0,04	0,08	0,10	min.						60							
					11,900 - 18,899	0,10	0,20	0,25	0,05	0,10	0,13								norm					80	
					18,900 - 32,599	0,10	0,20	0,30	0,07	0,11	0,16								max.					100	
					32,600 - 60,599	0,20	0,30	0,40	0,09	0,13	0,18														
M	High alloy steels X6CrMo4/1.2341 X165CrMoV12/1.2601			5,600 - 11,899	0,10	0,15	0,20	0,04	0,05	0,10	min.	4	15				30								
				11,900 - 18,899	0,10	0,20	0,25	0,05	0,08	0,12								norm	5	30	45				
				18,900 - 32,599	0,10	0,20	0,30	0,06	0,10	0,14								max.	7	45	60				
				32,600 - 60,599	0,20	0,30	0,40	0,07	0,12	0,15															
	Stainless steel X2CrNi189/1.4306 X5CrNiMo1810/1.4401	<600			5,600 - 11,899	0,10	0,15	0,20	0,04	0,06	0,10	min.	5	15				30							
					11,900 - 18,899	0,10	0,20	0,25	0,05	0,06	0,12								norm	6	30	45			
					18,900 - 32,599	0,10	0,20	0,30	0,06	0,12	0,16								max.	8	40	60			
					32,600 - 60,599	0,20	0,30	0,40	0,07	0,14	0,20														
	Stainless steel / heatproof steel X8CrNb17/1.4511 X10CrAl7/1.4713 X8Cr5-38-18/1.4862	>600			5,600 - 11,899	0,10	0,15	0,20	0,04	0,06	0,10	min.	4	10				20							
					11,900 - 18,899	0,10	0,20	0,25	0,05	0,06	0,12								norm	5	20	35			
					18,900 - 32,599	0,10	0,20	0,30	0,06	0,12	0,16								max.	6	35	50			
					32,600 - 60,599	0,20	0,30	0,40	0,07	0,14	0,20														
S	Special alloys Inconel Nimonic Hastelloy	250		5,600 - 11,899	0,10	0,15	0,20	0,05	0,08	0,11	min.		10				10								
				11,900 - 18,899	0,10	0,20	0,25	0,07	0,13	0,17								norm					30		
				18,900 - 32,599	0,10	0,20	0,30	0,10	0,16	0,24								max.					40		
				32,600 - 60,599	0,20	0,30	0,40	0,11	0,20	0,30															
	Titanium, titanium alloys TiAl55n2/3.7114	400			5,600 - 11,899	0,10	0,15	0,20	0,05	0,08	0,11	min.	5												
					11,900 - 18,899	0,10	0,20	0,25	0,07	0,13	0,17								norm	10					
					18,900 - 32,599	0,10	0,20	0,30	0,10	0,16	0,24								max.	16					
					32,600 - 60,599	0,20	0,30	0,40	0,11	0,20	0,30														
60,600 - 205,599	0,30	0,40	0,50	0,12	0,22	0,35																			

For face cutting geometries G06, G06A, G0611, G065, G065A feed fz to be reduced by 30 %.



# Recommended Cutting Data

The reamer specialist

For left hand fluted and straight fluted reamers  
Geometries G05, G05A, G09, G09B, G1405

Material group	Material	Strength N/mm <sup>2</sup>	Hardness HB	Reamer ø [mm]	Reaming allowance			Feed per tooth			Carbide	Cutting speed Vc = [m/min]				
					ø [mm]			Fz=mm / rev. per tooth				Carbide coated			CERMET coated	
					min.	norm	max.	min.	norm	max.		TiN	TiAlN	AlC	CERMET	TiAlN
P	Non-alloy and low alloy steels St37-2/1.0037 95Mn28/1.0715 St52-2/1.0050	<900	7,900 - 11,899	0,10	0,15	0,20	0,08	0,15	0,20	min.	6	60	60		100	100
			11,900 - 18,899	0,10	0,20	0,25	0,09	0,18	0,24							
			18,900 - 32,599	0,10	0,20	0,30	0,14	0,21	0,30							
			32,600 - 60,599	0,20	0,30	0,40	0,17	0,24	0,33							
			60,600 - 205,599	0,30	0,40	0,50	0,20	0,27	0,36							
	Lead alloyed steels, lead alloys 95MnPb28/1.0718		7,900 - 11,899	0,10	0,15	0,20	0,08	0,15	0,20	min.	20	60	60		100	100
			11,900 - 18,899	0,10	0,20	0,25	0,09	0,18	0,24							
			18,900 - 32,599	0,10	0,20	0,30	0,14	0,21	0,30							
			32,600 - 60,599	0,20	0,30	0,40	0,17	0,24	0,33							
			60,600 - 205,599	0,30	0,40	0,50	0,20	0,27	0,36							
	Non alloy and low alloy steels 42CrMo4/1.7225 CK60/1.1221	900 - 1300	7,900 - 11,899	0,10	0,15	0,20	0,08	0,15	0,20	min.	6	60	80		80	80
			11,900 - 18,899	0,10	0,20	0,25	0,09	0,17	0,21							
18,900 - 32,599			0,10	0,20	0,30	0,11	0,18	0,24								
32,600 - 60,599			0,20	0,30	0,40	0,12	0,21	0,30								
60,600 - 205,599			0,30	0,40	0,50	0,14	0,24	0,33								
H	Hardened steels <45HRC	1400	7,900 - 11,899							min.						
			11,900 - 18,899													
			18,900 - 32,599													
			32,600 - 60,599													
			60,600 - 205,599													
	Hardened steels 45 - 65HRC	1800	7,900 - 11,899							min.						
			11,900 - 18,899													
			18,900 - 32,599													
			32,600 - 60,599													
			60,600 - 205,599													
M	High alloy steels X6CrMo4/1.2341 X165CrMoV12/1.2601		7,900 - 11,899	0,10	0,15	0,20	0,06	0,08	0,15	min.	4	15		30		
			11,900 - 18,899	0,10	0,20	0,25	0,08	0,12	0,18							
			18,900 - 32,599	0,10	0,20	0,30	0,09	0,15	0,21							
			32,600 - 60,599	0,20	0,30	0,40	0,11	0,18	0,23							
			60,600 - 205,599	0,30	0,40	0,50	0,14	0,21	0,26							
	Stainless steel X2CrNi189/1.4306 X5CrNiMo1810/1.4401	<600	7,900 - 11,899	0,10	0,15	0,20	0,06	0,09	0,15	min.	5	15		30		
			11,900 - 18,899	0,10	0,20	0,25	0,09	0,14	0,18							
			18,900 - 32,599	0,10	0,20	0,30	0,11	0,18	0,24							
			32,600 - 60,599	0,20	0,30	0,40	0,12	0,21	0,30							
			60,600 - 205,599	0,30	0,40	0,50	0,14	0,24	0,33							
	Stainless steel / heatproof steel X8CrNb17/1.4511 X10CrAl7/1.4713 X8CrS-38-18/1.4862	>600	7,900 - 11,899	0,10	0,15	0,20	0,06	0,09	0,15	min.	4	10		20		
			11,900 - 18,899	0,10	0,20	0,25	0,09	0,14	0,18							
18,900 - 32,599			0,10	0,20	0,30	0,11	0,18	0,24								
32,600 - 60,599			0,20	0,30	0,40	0,12	0,21	0,30								
60,600 - 205,599			0,30	0,40	0,50	0,14	0,24	0,33								
S	Special alloys Inconel Nimonic Hastelloy	250	7,900 - 11,899							min.						
			11,900 - 18,899													
			18,900 - 32,599													
			32,600 - 60,599													
			60,600 - 205,599													
	Titanium, titanium alloys TiAl55n2/3.7114	400	7,900 - 11,899								min.					
			11,900 - 18,899													
			18,900 - 32,599													
			32,600 - 60,599													
			60,600 - 205,599													

# Recommended Cutting Data

The reamer specialist



Material group	Material	Strength N/mm <sup>2</sup>	Hardness HB	Reamer ø [mm]	Reaming allowance			Feed per tooth				Cutting speed Vc = [m/min]									
					min.	norm	max.	min.	norm	max.		Carbide	Carbide coated			CERMET	CERMET coated		PCD		
													TiAlN	TiAlN-P	ZrN		TiAlN	TiAlN-P			
K	Gray cast iron GG-25/0.6025 GG-35/0.6035		180	7,900 - 11,899																	
				11,900 - 18,899																	
				18,900 - 32,599																	
				32,600 - 60,599																	
				60,600 - 205,599																	
	Alloy gray cast iron GG-NiCr20/0.6660		250	7,900 - 11,899																	
				11,900 - 18,899																	
				18,900 - 32,599																	
				32,600 - 60,599																	
				60,600 - 205,599																	
	Spheroidal graphite cast iron, ferritic / perlitic GGG-40/0.7040 GGG-50/0.7050, GTW-55/0.8055		130 - 230	7,900 - 11,899																	
				11,900 - 18,899																	
				18,900 - 32,599																	
				32,600 - 60,599																	
				60,600 - 205,599																	
	Spheroidal graphite cast iron, perlite malleble iron GGG-60/0.7060 GTS-65/0.8165		250	7,900 - 11,899	0,10	0,15	0,20	0,08	0,13	0,16											
				11,900 - 18,899	0,10	0,20	0,25	0,10	0,16	0,23	min.	8	80	80		80	80	80			
				18,900 - 32,599	0,10	0,20	0,30	0,13	0,21	0,31	norm.	12	130	130		130	130	130			
				32,600 - 60,599	0,20	0,30	0,40	0,16	0,26	0,40	max.	15	180	180		180	180	180			
				60,600 - 205,599	0,30	0,40	0,50	0,18	0,31	0,43											
Alloyed spheroidal graphite cast iron, vermicular cast GGG-NiCr20-2/0.7661 GGV Ti <0.2 GGV Ti >0.2		200 - 300	7,900 - 11,899	0,10	0,15	0,20	0,08	0,13	0,16												
			11,900 - 18,899	0,10	0,20	0,25	0,10	0,16	0,23	min.	6	40	40								
			18,900 - 32,599	0,10	0,20	0,30	0,13	0,21	0,31	norm.	9	80	80								
			32,600 - 60,599	0,20	0,30	0,40	0,16	0,26	0,40	max.	12	120	120								
			60,600 - 205,599	0,30	0,40	0,50	0,18	0,31	0,43												
N	Copper alloy: brass, bronze good cut CuZn36Pb3/2.1182 G-CuPb15Sn/2.1182		90	7,900 - 11,899	0,10	0,15	0,20	0,08	0,13	0,16											
				11,900 - 18,899	0,10	0,20	0,25	0,10	0,16	0,23	min.	10				80	100				
				18,900 - 32,599	0,10	0,20	0,30	0,12	0,22	0,31	norm.	20				120	150				
				32,600 - 60,599	0,20	0,30	0,40	0,13	0,26	0,39	max.	30				160	300				
				60,600 - 205,599	0,30	0,40	0,50	0,14	0,30	0,43											
	Copper alloy: brass, bronze average cut CuZn40Al1/2.0550 E-Cu57/2.0060		100	7,900 - 11,899	0,10	0,15	0,20	0,08	0,13	0,16											
				11,900 - 18,899	0,10	0,20	0,25	0,10	0,16	0,23	min.	10				80	50				
				18,900 - 32,599	0,10	0,20	0,30	0,12	0,22	0,31	norm.	15				120	100				
				32,600 - 60,599	0,20	0,30	0,40	0,13	0,26	0,39	max.	30				160	150				
				60,600 - 205,599	0,30	0,40	0,50	0,14	0,30	0,43											
	Wrought aluminium alloys AlMg1/3.3315 AlMnCu/3.0517		60	7,900 - 11,899	0,10	0,15	0,20	0,08	0,13	0,16											
				11,900 - 18,899	0,10	0,20	0,25	0,10	0,16	0,23	min.	10				50				110	
				18,900 - 32,599	0,10	0,20	0,30	0,12	0,22	0,31	norm.	20				150				220	
				32,600 - 60,599	0,20	0,30	0,40	0,13	0,26	0,39	max.	30				300				330	
				60,600 - 205,599	0,30	0,40	0,50	0,14	0,30	0,43											
	Cast aluminium alloy: <8 % Si, magne- sium alloy G-AlMg5/3.3561		75	7,900 - 11,899	0,10	0,15	0,20	0,08	0,13	0,16											
				11,900 - 18,899	0,10	0,20	0,25	0,10	0,16	0,23	min.	10				150				110	
				18,900 - 32,599	0,10	0,20	0,30	0,12	0,22	0,31	norm.	20				200				300	
				32,600 - 60,599	0,20	0,30	0,40	0,13	0,26	0,39	max.	30				300				550	
				60,600 - 205,599	0,30	0,40	0,50	0,14	0,30	0,43											
Cast aluminium alloy: >8 % Si G-AlSi9Mg/3.2373 G-AlSi10Mg/3.2381		100	7,900 - 11,899																		
			11,900 - 18,899																110		
			18,900 - 32,599																	250	
			32,600 - 60,599																	440	
			60,600 - 205,599																		

Cutting datas

$$V_f \text{ [mm/min]} = n \text{ [min}^{-1}\text{]} \times f_z \text{ [mm]} \times z \text{ [No. of teeth]}$$

$$n \text{ [min}^{-1}\text{]} = \frac{V_c \text{ [m/min]} \times 1000}{\pi \times \phi \text{ [mm]}}$$

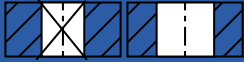
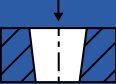
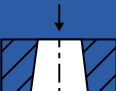
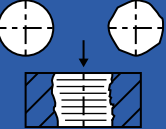
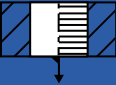
# Correction of Reaming Problems

Problem	Cause	Corrective action
<p>1. Bore too big</p> 	<p>a) Reamer is not running true in the machine  b) Alignment is not precise, reamer cuts at the back end  c) Built-up edges  d) Coolant is inappropriate  e) Reamer is too big</p>	<p>a) Use a Compensation holder  b) Correct the alignment, use Compensation holder or event. Floating holder  c) Use another coolant, reduce the cutting speed  d) Use another coolant  e) Use a smaller reamer</p>
<p>2. Bore too small</p> 	<p>a) Reamer is too small  b) Reamer is blunt  c) Coolant is inappropriate  d) Reaming allowance is too small  e) Cutting speed too low or feed too high</p>	<p>a) Use larger or reworked reamer  b) Have the reamer reworked  c) Use another coolant  d) Select the reaming allowance from the table (Page 76 - 79)  e) Select cutting data from the table (Page 76 - 79)</p>
<p>3. Tapered Bore</p> 	<p>a) Misalignment, Blades press at start.  b) Reamer cuts at the back end</p>	<p>a) Correct the alignment, use Compensation holder or event. Floating holder  b) Correct the tailstock, use Compensation holder or event. Floating holder</p>
<p>4. Lipped bore</p> 	<p>a) Inaccurate alignment  b) Misalignment between headstock and tailstock</p>	<p>a) Correct the alignment, use Compensation holder or event. Floating holder  b) Correct the tailstock, use Compensation holder or event. Floating holder</p>
<p>5. Bore is not true, shows chatter marks</p> 	<p>a) Fault of concentricity or alignment of the reamer in the machine  b) Asymmetrical cutting of the reamer  c) Deformation through clamping of the workpiece</p>	<p>a) Correct the true running/alignment of the reamer, use Compensation holder  b) Countersink the bore  c) Correct the fixation of the workpiece</p>
<p>6. Grooves in the bore "feed marks"</p> 	<p>a) Reamer does not run true in the machine  b) Material built-up on cutting edges</p>	<p>a) Use a Compensation holder, possibly the reamer has to be reworked  b) Reduce cutting speed</p>
<p>7. Quality of the surface is unsatisfactory</p> 	<p>a) Cutting edges are blunt or notched  b) Bevel is uneven  c) Reamer does not run true  d) Wrong machining data  e) None or insufficient coolant supply, chips are jammed</p>	<p>a) Have the reamer retipped  b) Have the bevel reground  c) Adjust the reamer with a Compensation holder  d) Correct machining data referring to table (application data)  e) Increase coolant pressure, use reamer with internal coolant supply</p>
<p>8. Reamer is jamming</p> 	<p>a) Conical/taper form of the reamer is too small by wearout or loosening of the cone screw  b) Circular land too wide  c) Coolant is inappropriate</p>	<p>a) Have the reamer reworked  b) Relief angle to be reground  c) Use another coolant</p>



# Questionnaire

The reamer specialist

For the definition of the ideal reaming tool

Company:	Date:
Address:	Customer contact:
<b>1. Material to be machined</b>	<b>3. Tool shank and coolant supply</b>
Standard designation:	Morse taper: <span style="float: right;">MT</span>
Heat treatment:	ZStraight shank: <span style="float: right;">∅</span>
Tensile strength:	Other tool shanks:
<b>2. Bore</b>	Machining: <span style="float: right;">horizontal <input type="checkbox"/> vertical <input type="checkbox"/></span>
∅ and tolerance:	Tool: <span style="float: right;">fixed <input type="checkbox"/> rotating <input type="checkbox"/></span>
∅ of the prereaming:	Coolant supply through tool: <span style="float: right;">Yes <input type="checkbox"/> No <input type="checkbox"/></span>
Method of prereaming:	<b>4. Coolant</b>
Length of bore:	Brand and style:
Through holes: <input type="checkbox"/> <span style="margin-left: 100px;">Blind holes: <input type="checkbox"/></span>	Concentration: <span style="float: right;">%</span>
Bottom also to be machined? <span style="margin-left: 20px;">Yes <input type="checkbox"/></span> <span style="margin-left: 40px;">No <input type="checkbox"/></span>	Coolant pressure available: <span style="float: right;">bar</span>
Interrupted hole: <span style="margin-left: 20px;">Yes <input type="checkbox"/></span> <span style="margin-left: 40px;">No <input type="checkbox"/></span>	<b>5. Machine</b>
If yes, length of interruption:	Brand and style:
Surface finish Ra   Rt   Rz:	Feed <span style="float: right;">fixed <input type="checkbox"/> variable <input type="checkbox"/></span>
Circular error permitted:	Speed <span style="float: right;">fixed <input type="checkbox"/> variable <input type="checkbox"/></span>
Cylindricity to be obtained:	True running accuracy of the spindle:
Other quality requirements:	<b>6. Volume of production</b>
	Number of holes per year:
	Batch volume:
<b>7. Workpiece and workpiece clamping</b> <span style="float: right;">Please enclose a drawing of the workpiece or make a sketch here</span>	

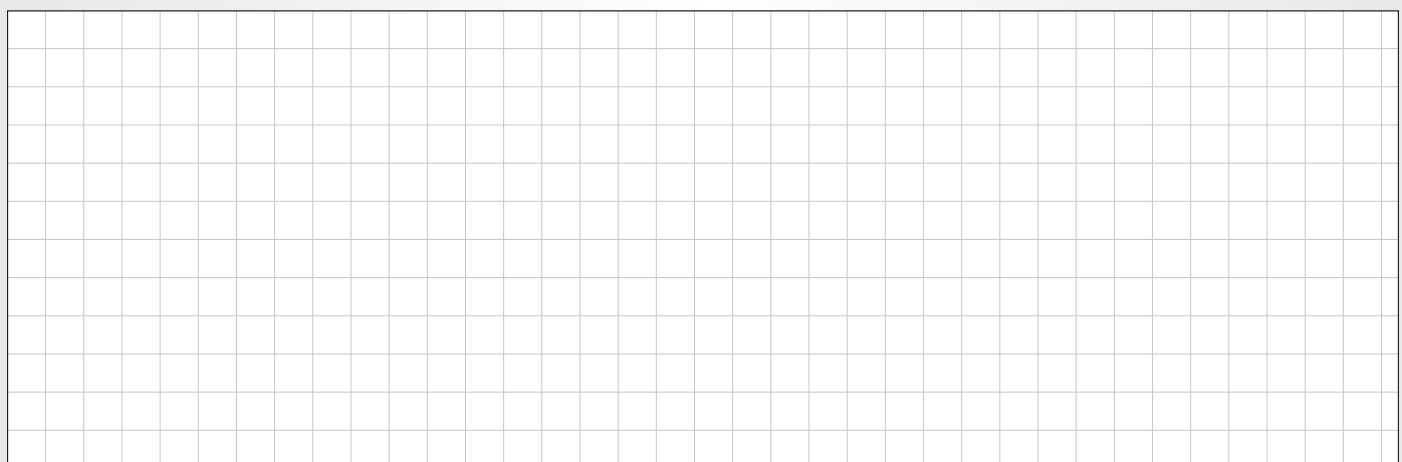

Retipping + coating with original quality made in Germany.

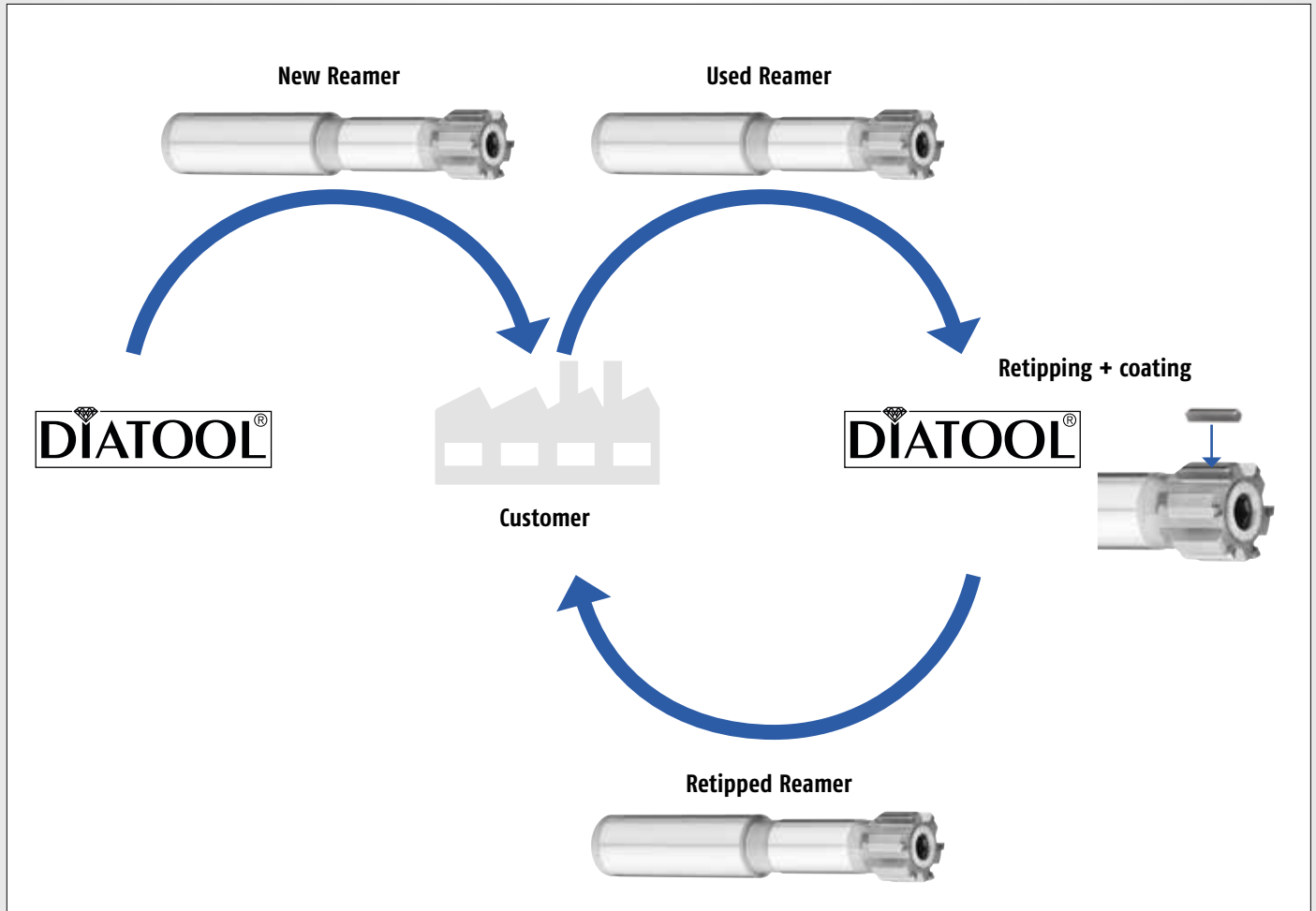

**Advantage:**

- Re-tipped reamers are "as good as new"
- We re-tip a reamer an unlimited number of times
- Re-tipping is economical

**Products:**



Other Brands

**Cutting material:**

HM	Cermet	PKD
----	--------	-----

**Coating:**

TiN	TiAlN	TiAlN-P	TiAlN-L	ATN	ATC	ZCN
-----	-------	---------	---------	-----	-----	-----

Experience Diatool:



DIATOO-Imagefilm

<https://youtu.be/Wu5IAGaH5Ps>



Always up to date:



[www.diatool.de](http://www.diatool.de)





**DIATool®**

**DIATool Präzisionswerkzeug GmbH**

Schildgasse 31 - 33  
DE-79618 Rheinfeldern, Germany

Tel.: 00 49 (0) 76 23-79 96 66

Fax: 00 49 (0) 76 23-79 91 77

E-Mail: [info@diatool.de](mailto:info@diatool.de)